

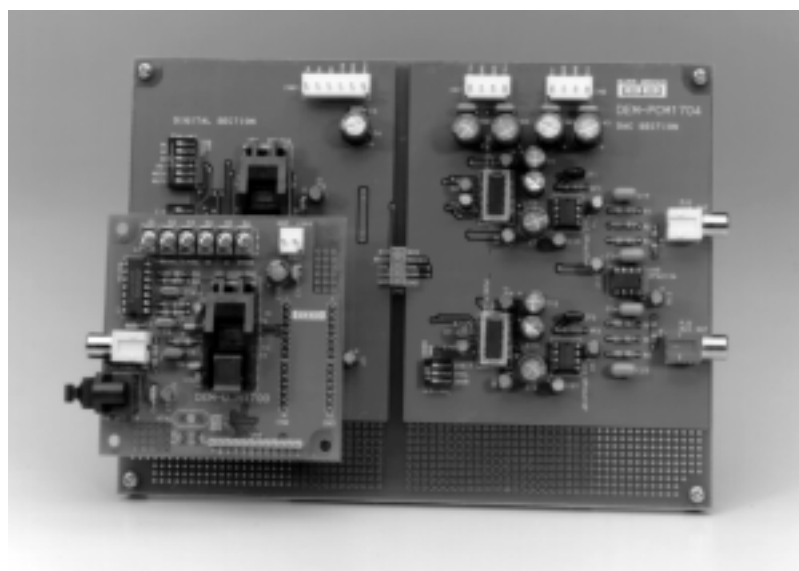

# DEM-PCM1704 EVALUATION FIXTURE



## FEATURES

- INCLUDES TWO PCM1704s, A DF1704 8X INTERPOLATION FILTER, I/V CONVERTERS AND DAC POST FILTERS
- REQUIRES  $\pm 5V$  SUPPLIES FOR THE PCM1704 DACs, UP TO  $\pm 18V$  SUPPLIES FOR THE OP AMPS, AND A SINGLE  $+5V$  SUPPLY FOR THE DIGITAL SECTION
- 28-PIN DIP SOCKET FOR DEM-DIR1700 DIGITAL AUDIO RECEIVER ADAPTOR BOARD
- INTERFACE CABLE FOR INTERFACING TO A PC PARALLEL PORT<sup>(1)</sup>
- DEMONSTRATION SOFTWARE FOR PROGRAMMING DF1704 INTERNAL REGISTERS<sup>(1)</sup>

## DESCRIPTION

The DEM-PCM1704 is a complete evaluation fixture for the PCM1704 24-bit sign-magnitude digital-to-analog converter and the DF1704 8X interpolation filter. It includes a demonstration board, PC interface cable, and software for controlling the DF1704 filter.

The demonstration board includes all necessary power supply and interface connectors. A socket is provided for accommodating the DEM-DIR1700 demo board. Analog signal conditioning circuitry for the DAC outputs is also included.

## BLOCK DIAGRAM

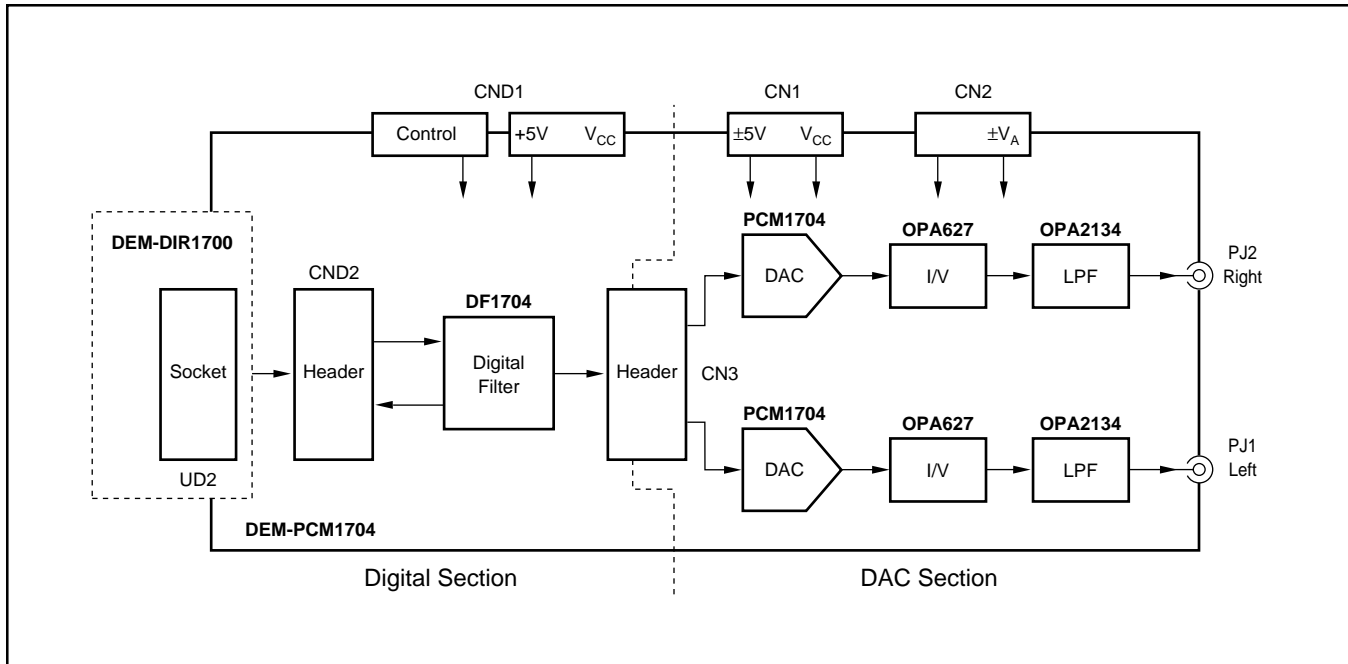

## HARDWARE DESCRIPTION

This section describes the hardware components of the DEM-PCM1704 demonstration board.

### DAC SECTION

The DAC section of the demonstration board includes two PCM1704Us, two OPA627s used as current-to-voltage (I/V) converters, and a OPA2134 dual op amp used to provide second-order lowpass filters for the right and left audio channels. Connectors are provided for power supplies and interfacing to the digital section or an external digital host.

#### Connectors

Connector CN1 is used to provide power to the PCM1704 DACs.  $+V_{CC}$  should be set for  $+5V_{DC}$ , and  $-V_{CC}$  should be set for  $-5V_{DC}$ .

Connector CN2 is used to provide power to the OPA627 and OPA2134 op amps.  $+V_A$  is typically set for  $+15V_{DC}$  (maximum is  $+18V_{DC}$ ), while  $-V_{CC}$  is typically set to  $-15V_{DC}$  (maximum is  $-18V_{DC}$ ).

The GND pins on connectors CN1 and CN2 are connected to the analog ground plane of the DAC section.

CN3 is used to connect the audio interface of the digital section to the PCM1704 DACs. Normally, jumpers should be installed for BCK, WDCK, DOL, DOR, and GND. However, if the user desires to bypass the circuitry of the digital section and drive the DACs directly from another signal source, this can be accomplished through this connector.

RCA jacks PJ1 and PJ2 provide the left and right audio channel outputs. They provide straight forward connection to measurement and commercial audio equipment.

### Switches

DIP switch SW0 is used to set up the data format for the two PCM1704 DACs. Table I shows the function of the DIP switch settings.

SW0	FUNCTION	SETTINGS
20-BIT	Selects Data Word Length	H = 24 Bits, L = 20 Bits
INVL	Selects Phase for Left Channel DAC	H = Normal, L = Inverted
INVR	Selects Phase for Right Channel DAC	H = Normal, L = Inverted

TABLE I. DAC Data Format Configuration.

### DIGITAL SECTION

The digital section of the DEM-PCM1704 demonstration board includes the DF1704 digital filter, DIP switches for configuring the filter, a connector for the PC interface cable and digital power supply, and a header for the input data interface. A socket is provided for the DEM-DIR1700 digital audio receiver adaptor board so that clocks and data can be derived from a standard S/PDIF input source.

#### Connectors

Connector CND1 is used to provide the  $+5V$  digital power supply and ground connections. It is also used to provide connection with an external host when using the DF1704 digital filter in Software control mode. The PC interface cable which accompanies the DEM-PCM1704 kit can be used to provide the connection with a PC parallel (or printer) port to control the MC, MD, ML, and RST signals. The cable also includes two banana plugs for connection to an external  $+5V$  supply.

Connector CND2 is used to provide the audio input data interface. CND2 can be connected to an external source, or

it can be configured to function with the DEM-DIR1700 adaptor board, which plugs into socket UD2. The DEM-DIR1700 adaptor board includes Burr-Brown's DIR1700 digital audio receiver. This module can be used to connect to an S/PDIF or optical audio interface used by measurement and commercial audio equipment, such as CD and DVD players.

### Switches

DIP switches SW1 and SW2 are used to set the configuration of the DF1704 digital filter. The DF1704 can be controlled using Hardware or Software modes, which is determined by the logic state of the MODE switch.

Table II shows the operation of DIP switch SW1.

SW1	DESCRIPTION
ML (RESV)	Software Mode: Control Port Word Clock Signal—set switch to H Hardware Mode: Reserved, Not Used
MC (LRIP)	Software Mode: Control Port Bit Clock—set switch to H Hardware Mode: LRCIN Polarity LRIP = H, then H = Left Channel, L = Right Channel LRIP = L, then H = Right Channel, L = Left Channel
MD (CKO)	Software Mode: Control Port Data—set switch to H Hardware Mode: CLKO Output Frequency CKO = H, then CLKO frequency = XT1/2 CKO = L, then CLKO frequency = XT1
RST	Reset: H = Normal Operation; L = Reset Operation
MODE	Mode Control: H = Software Mode, L = Hardware Mode
MUTE	Mute Control (ignored in Software mode) H = Mute Off—Normal Operation; L = Mute On

TABLE II. SW1 Operation (Hardware mode descriptions of dual mode pins shown in parentheses).

Table III shows the operation of DIP switch SW2 in Hardware mode. SW2 settings are ignored in Software mode.

SW2	DESCRIPTION
I <sup>2</sup> S	Input Data Format Controls
IW0	
IW1	<b>I<sup>2</sup>S IW1 IW0 INPUT FORMAT</b>
	L L L 16-Bit, Standard, MSB-First, Right-Justified
	L L H 20-Bit, Standard, MSB-First, Right-Justified
	L H L 24-Bit, Standard, MSB-First, Right-Justified
	L H H 24-Bit, MS-First, Right-Justified
	H L L 16-Bit, I <sup>2</sup> S
	H L H 24-Bit, I <sup>2</sup> S
SRO	Digital Filter Roll-Off: H = Slow, L = Sharp
OW0	Output Data Format Controls
OW1	<b>OW1 OW0 OUTPUT FORMAT</b>
	L L 16-Bit, MSB-First
	L H 18-Bit, MSB-First
	H L 20-Bit, MSB-First
	H H 24-Bit, MSB-First
SF0	Sample Rate Selection for De-Emphasis Control
SF1	<b>SF1 SF0 SAMPLING RATE</b>
	L L 44.1kHz
	L H Reserved
	H L 48kHz
	H H 32kHz
DEM	Digital De-Emphasis: H = On, L = Off

TABLE III. SW2 Operation (Hardware mode only).

### SCHEMATICS

Figure 1 shows the circuit connections for the digital section of the demonstration board. Figure 2 shows the circuit diagram for the DAC Section of the demonstration board.

The information provided herein is believed to be reliable; however, BURR-BROWN assumes no responsibility for inaccuracies or omissions. BURR-BROWN assumes no responsibility for the use of this information, and all use of such information shall be entirely at the user's own risk. Prices and specifications are subject to change without notice. No patent rights or licenses to any of the circuits described herein are implied or granted to any third party. BURR-BROWN does not authorize or warrant any BURR-BROWN product for use in life support devices and/or systems.

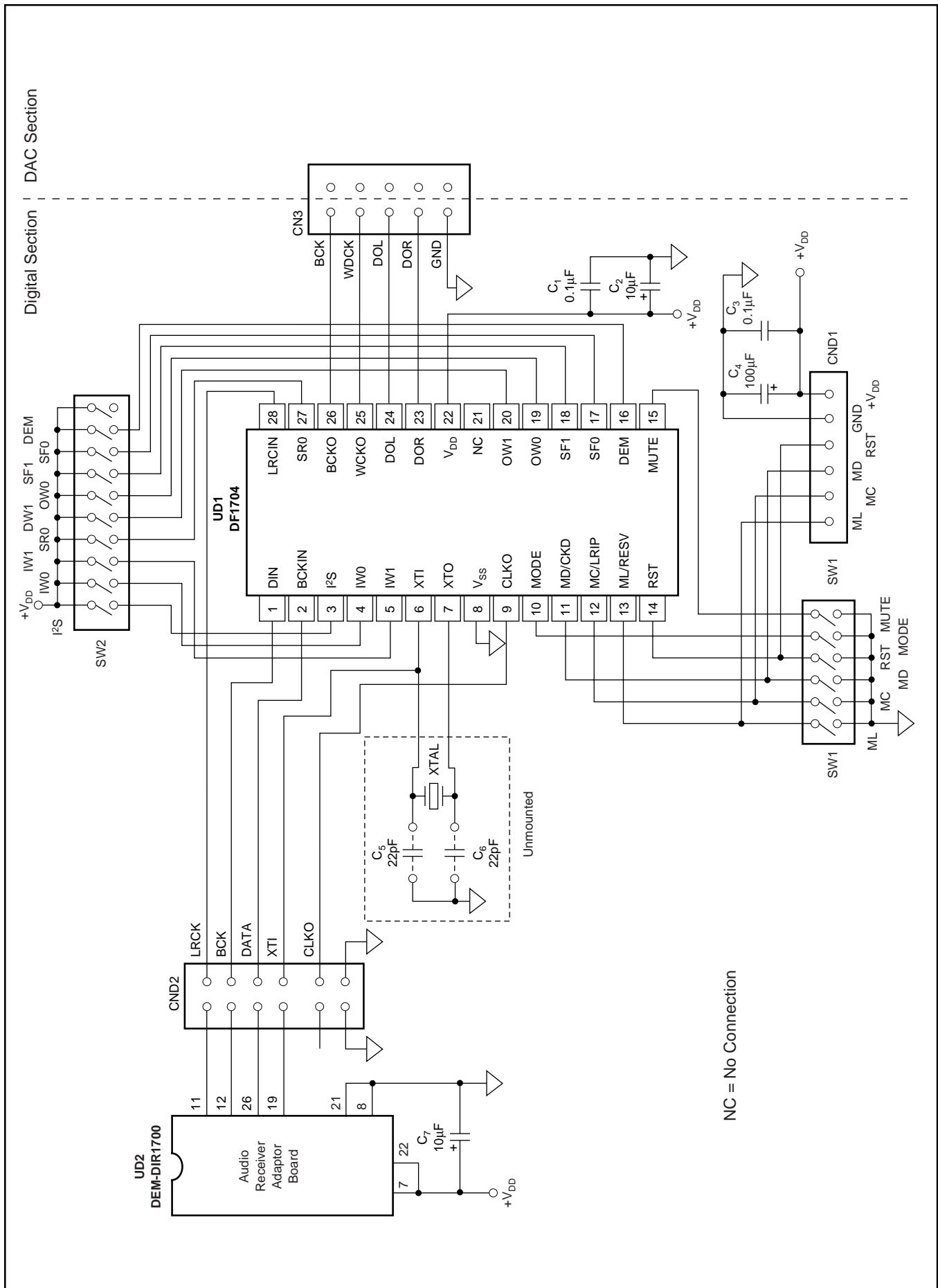

FIGURE 1.

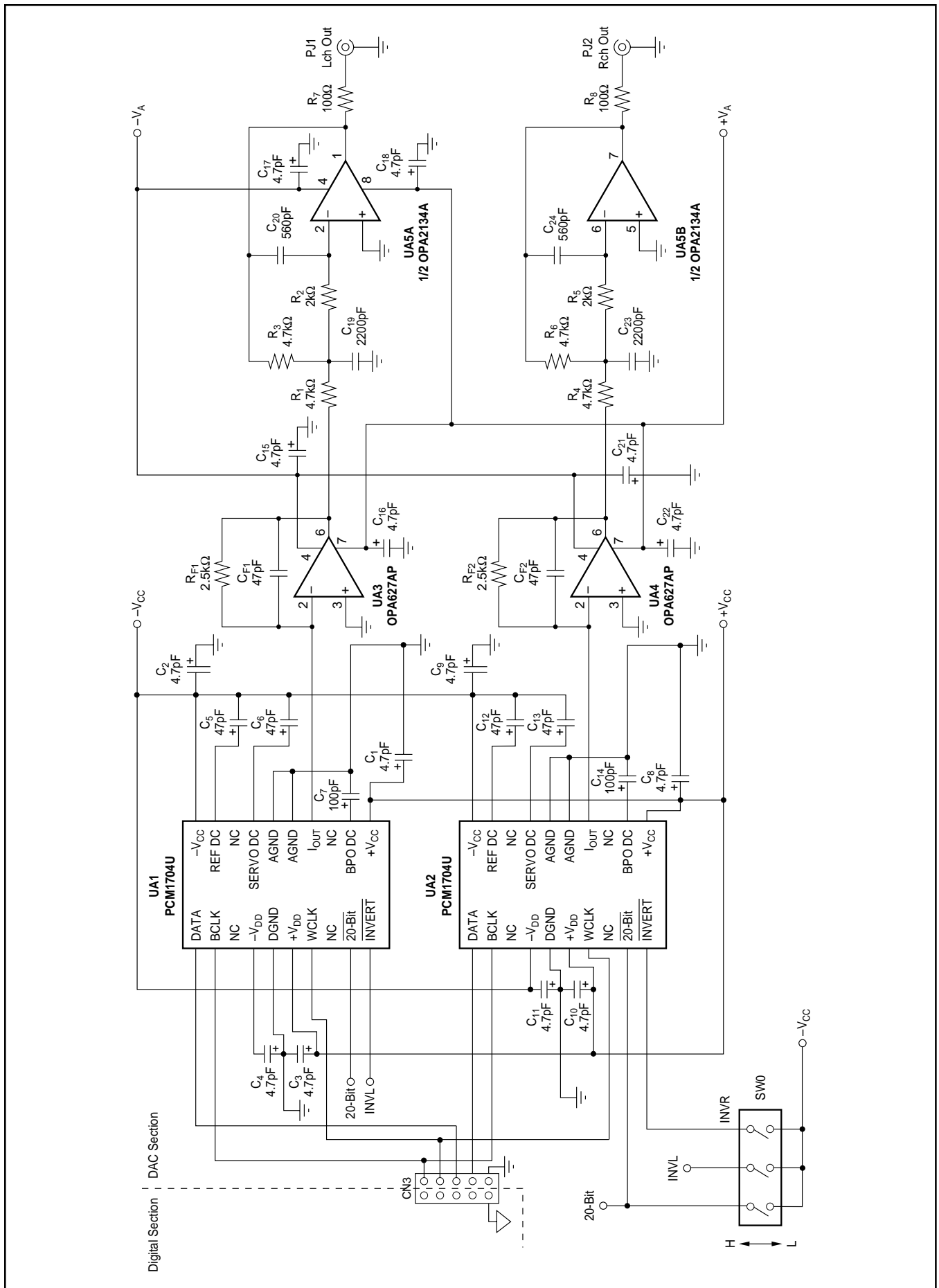

FIGURE 2. DAC Section.