

Blatt 1: der Anschluss an den Z80

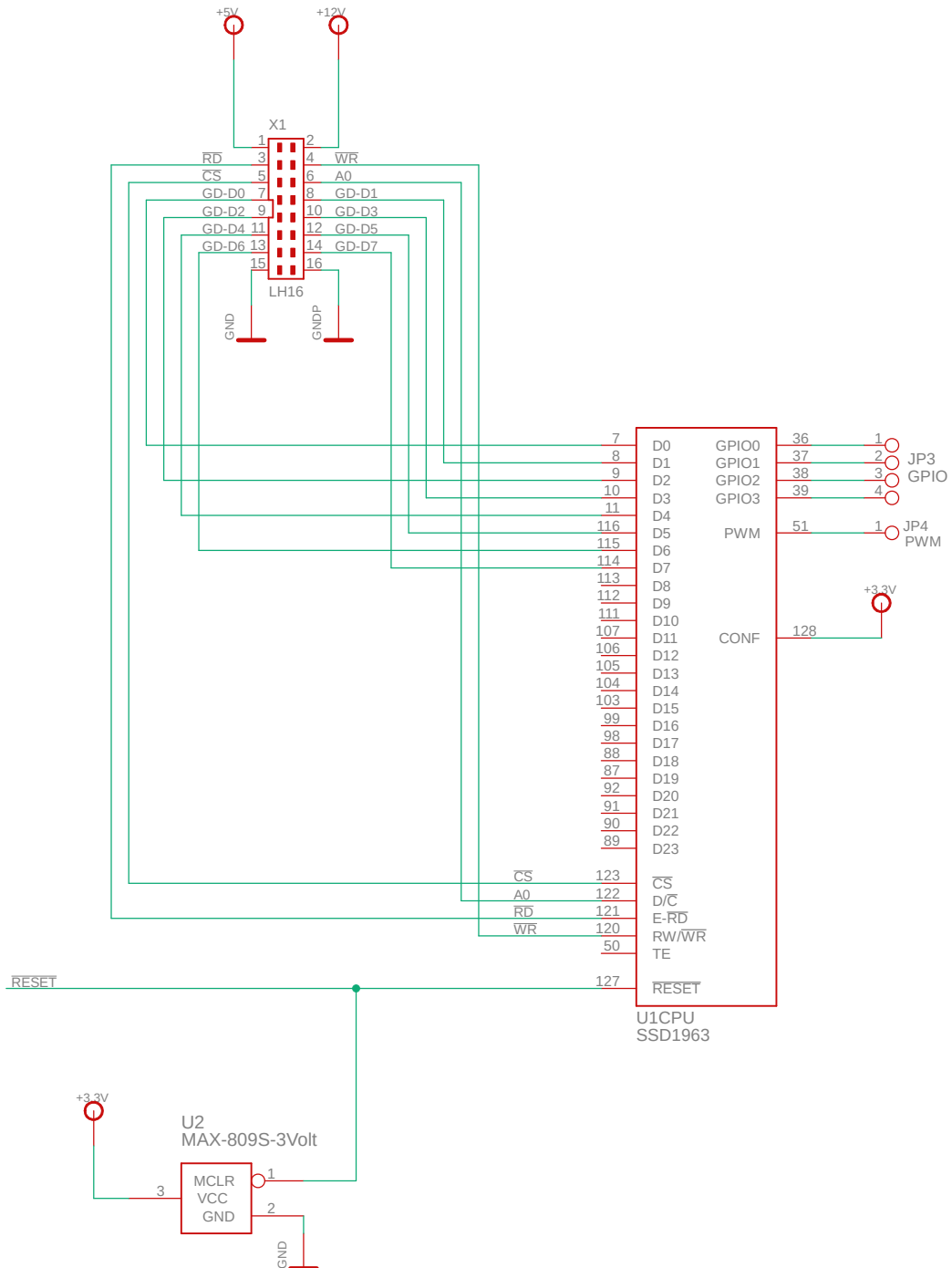

Blatt 2: die Display-Anschlüsse

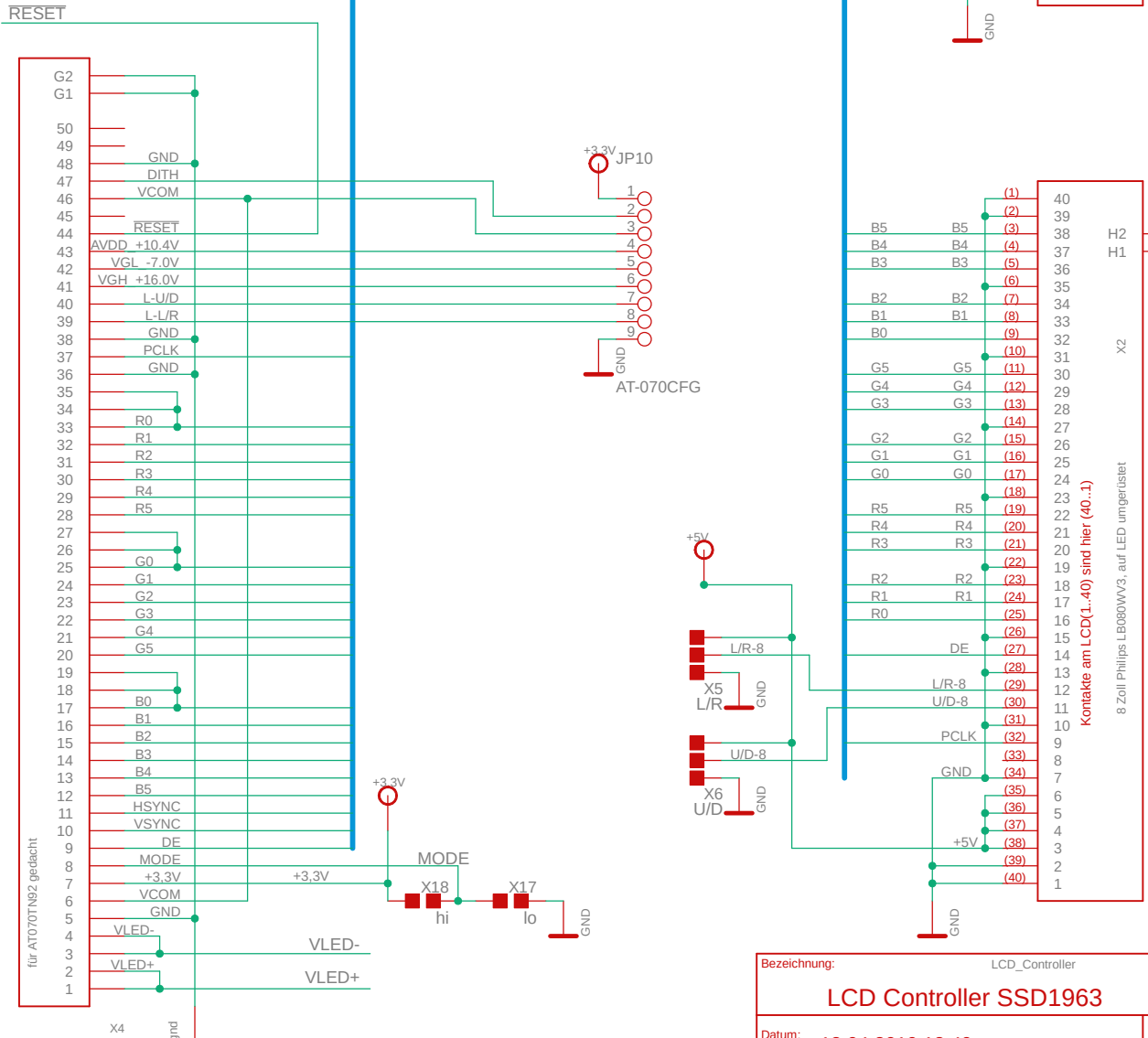
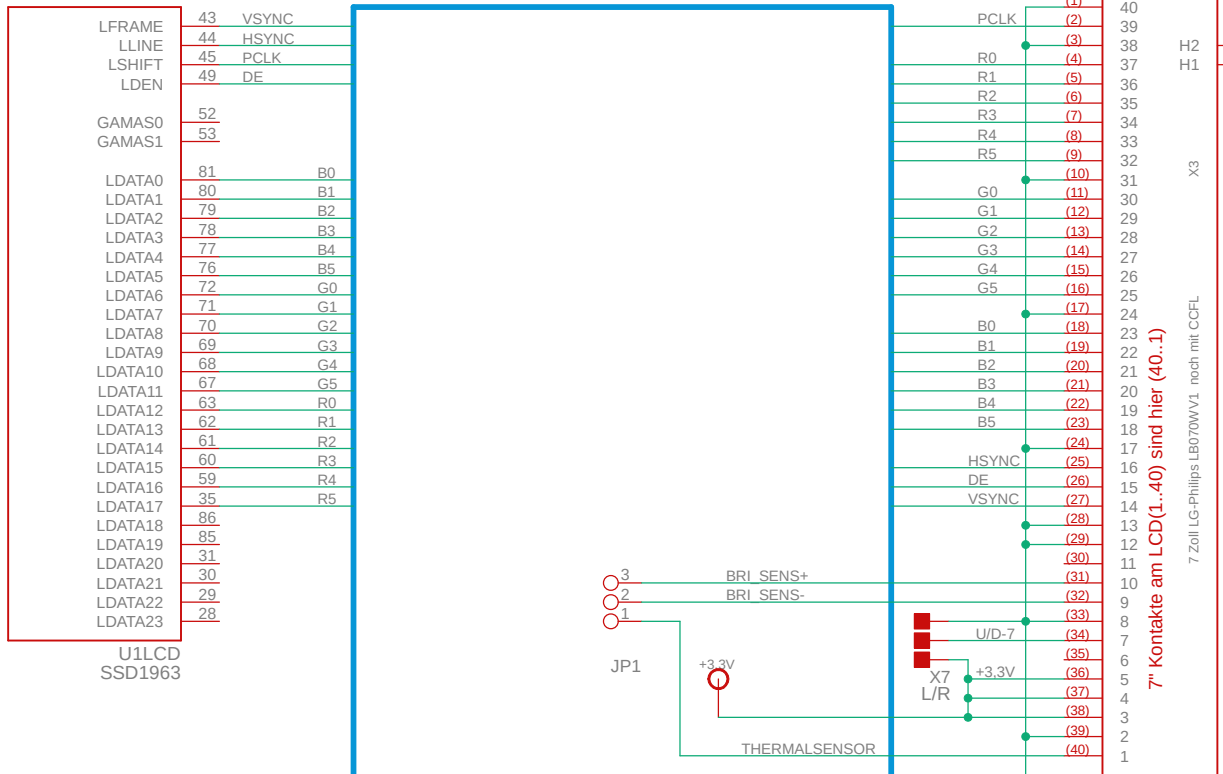

Blatt 3: die Stromversorgungen

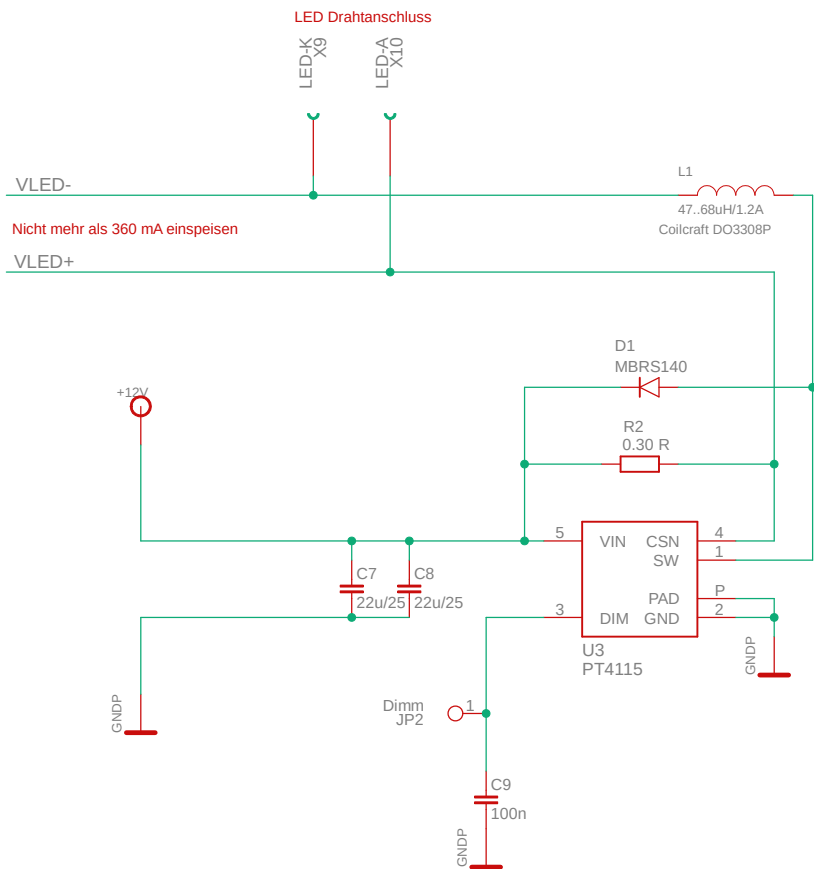
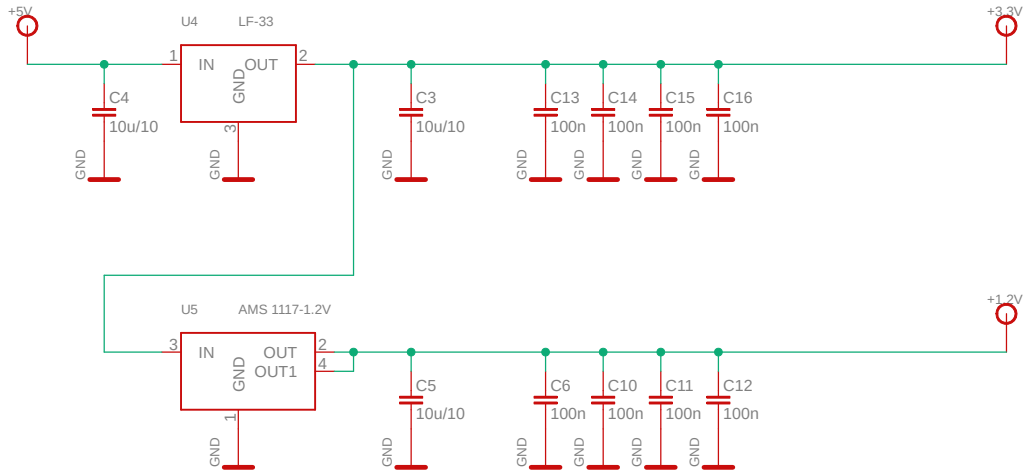

- merke: $U(R1) = 100 \text{ mV}$
- OR1 = 1 Ampere
- OR2 = 0.5 Ampere
- OR3 = 0.33 Ampere
- OR47 = 0.21 Ampere
- OR68 = 0.15 Ampere
- 1R0 = 0.1 Ampere
- 1R5 = 0.067 Ampere

| | | |
|-------------------------------|------------------|---------------|
| Bezeichnung: | LCD_Controller | |
| LCD Controller SSD1963 | | |
| Datum: | 12.04.2019 13:40 | Blatt: 3/4 |

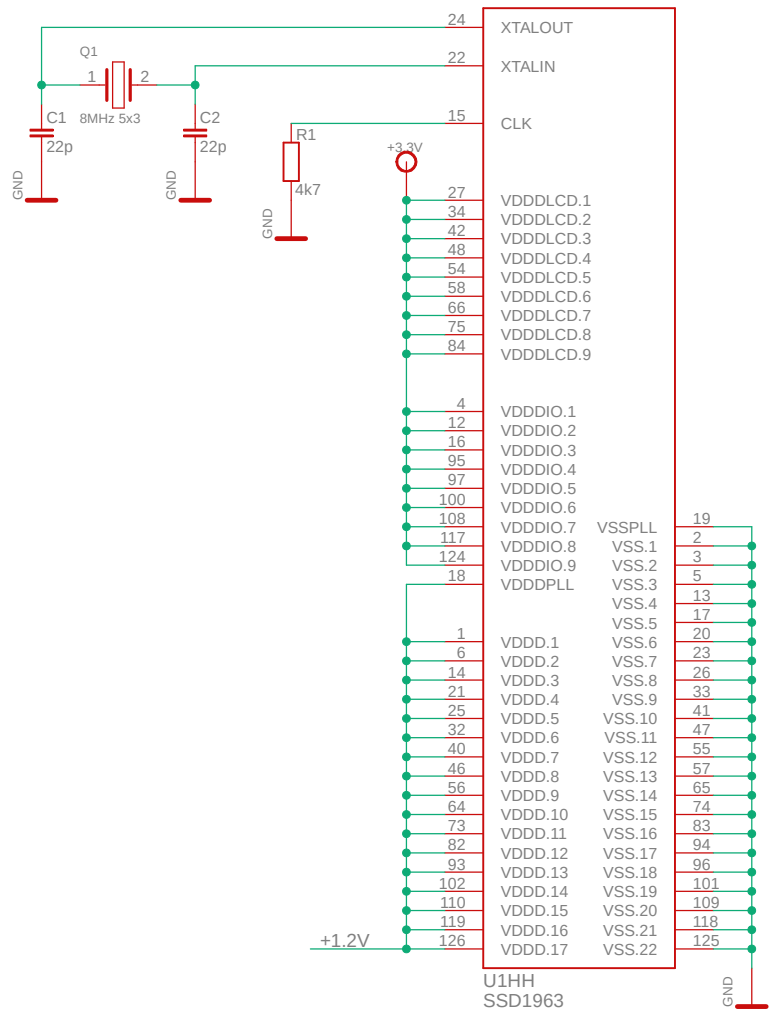

| | | |
|-------------------------------|------------------|------------|
| Bezeichnung: | LCD_Controller | |
| LCD Controller SSD1963 | | |
| Datum: | 12.04.2019 13:40 | Blatt: 4/4 |

LH-16'KRAGENSTIFTLISTE_90GRAD_MIT_VERRIEGELUNG'

