

High-Brightness LED Matrix Manager for Automotive Headlight Systems

1 Features

- 12 Series LED Bypass Switches
- Multi-Drop UART Communication Interface
- Programmable 10-bit PWM Dimming
 - Individual Turn-on and Turn-off Times
 - Inherent Phase Shift Capability
 - Device-to-Device Synchronization
- LED Open/Short Detection and Protection
 - Fault Reporting
- AEC-Q100 Grade 1
- Thermally Enhanced Package
 - 48-pin, TQFP, Exposed Pad Package

2 Applications

- Automotive headlight systems
- High-Brightness LED Matrix Systems

3 Description

The TPS92661 device is a compact, highly-integrated solution for shunt FET dimming for large arrays of high-brightness LEDs in applications such as automotive headlights.

The TPS92661 device includes a 12-switch series array for bypassing individual LEDs in the string and a serial communication interface for control and management by a master microcontroller.

An on-board charge pump rail that can float up to 67 V above GND provides the LED bypass switch gate drive. The low on-resistance ($R_{DS(on)}$) of the bypass switch minimizes conduction loss and power dissipation.

The TPS92661 device contains a multi-drop universal asynchronous receiver transmitter (UART) for serial communication. The turn-on and turn-off times are programmable for each individual LED in the string. The PWM frequency is adjustable via an internal register and multiple devices can be synchronized to the same frequency and phase.

The TPS92661 device features open LED protection as well as open and short LED fault reporting via the serial interface.

The TQFP package features a feed-through topology to enable easy routing of signals on single-layer metal core LED load boards.

Device Information⁽¹⁾

PART NUMBER	PACKAGE	BODY SIZE (NOM)
TPS92661-Q1	PHP (48)	7.00 mm x 7.00 mm

(1) For all available packages, see the orderable addendum at the end of the datasheet.

Simplified System Schematic

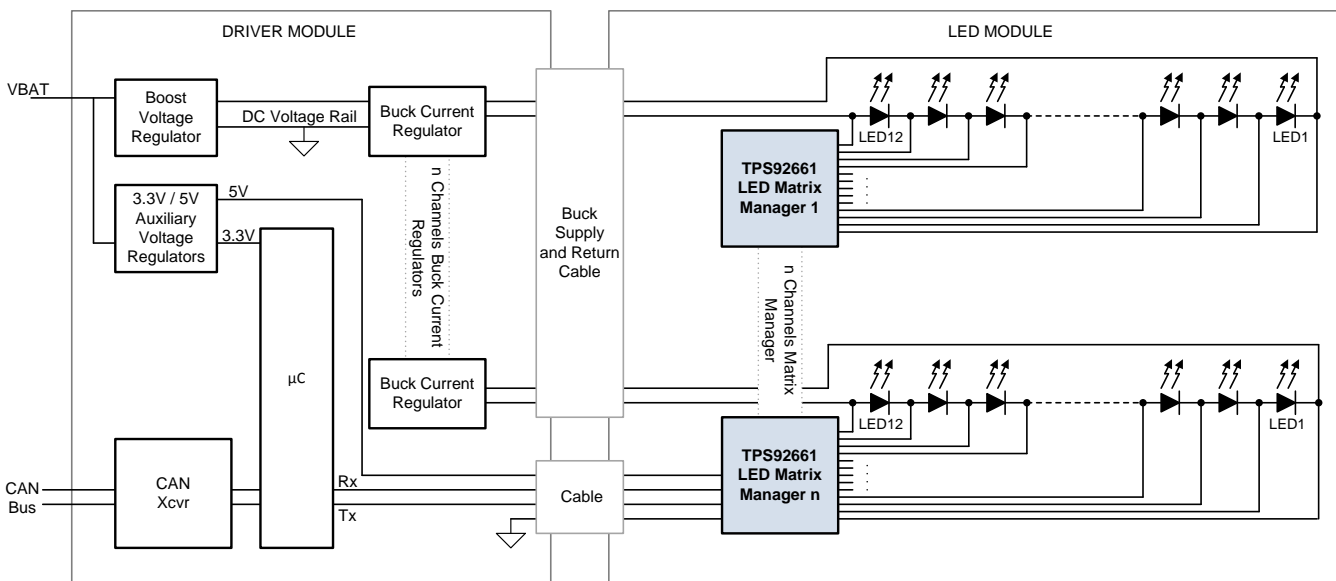

An IMPORTANT NOTICE at the end of this data sheet addresses availability, warranty, changes, use in safety-critical applications, intellectual property matters and other important disclaimers. PRODUCTION DATA.

Table of Contents

1 Features 1 2 Applications 1 3 Description 1 4 Revision History 2 5 Pin Configuration and Functions 3 6 Specifications 4 6.1 Absolute Maximum Ratings 4 6.2 Handling Ratings 5 6.3 Recommended Operating Conditions 5 6.4 Thermal Information 5 6.5 Electrical Characteristics 6 6.6 Typical Characteristics 7 7 Detailed Description 9 7.1 Overview 9 7.2 Functional Block Diagram 10 7.3 Feature Description 10 7.4 Device Functional Modes 20 7.5 Programming 31 7.6 Register Map 35	8 Application and Implementation 38 8.1 Applications Information 38 8.2 Design Examples 38 9 Power Supply Recommendations 40 9.1 General Recommendations 40 9.2 Internal Regulator 40 9.3 Power Up and Reset 41 9.4 VIN Power Consumption 41 9.5 Initialization Set-Up 41 10 Layout 43 10.1 Layout Guidelines 43 10.2 Layout Example 43 11 Device and Documentation Support 44 11.1 Trademarks 44 11.2 Electrostatic Discharge Caution 44 11.3 Export Control Notice 44 11.4 Glossary 44 12 Mechanical, Packaging, and Orderable Information 45
---	---

4 Revision History

NOTE: Page numbers for previous revisions may differ from page numbers in the current version.

DATE	REVISION	NOTES
September 2014	*	Initial release.

5 Pin Configuration and Functions

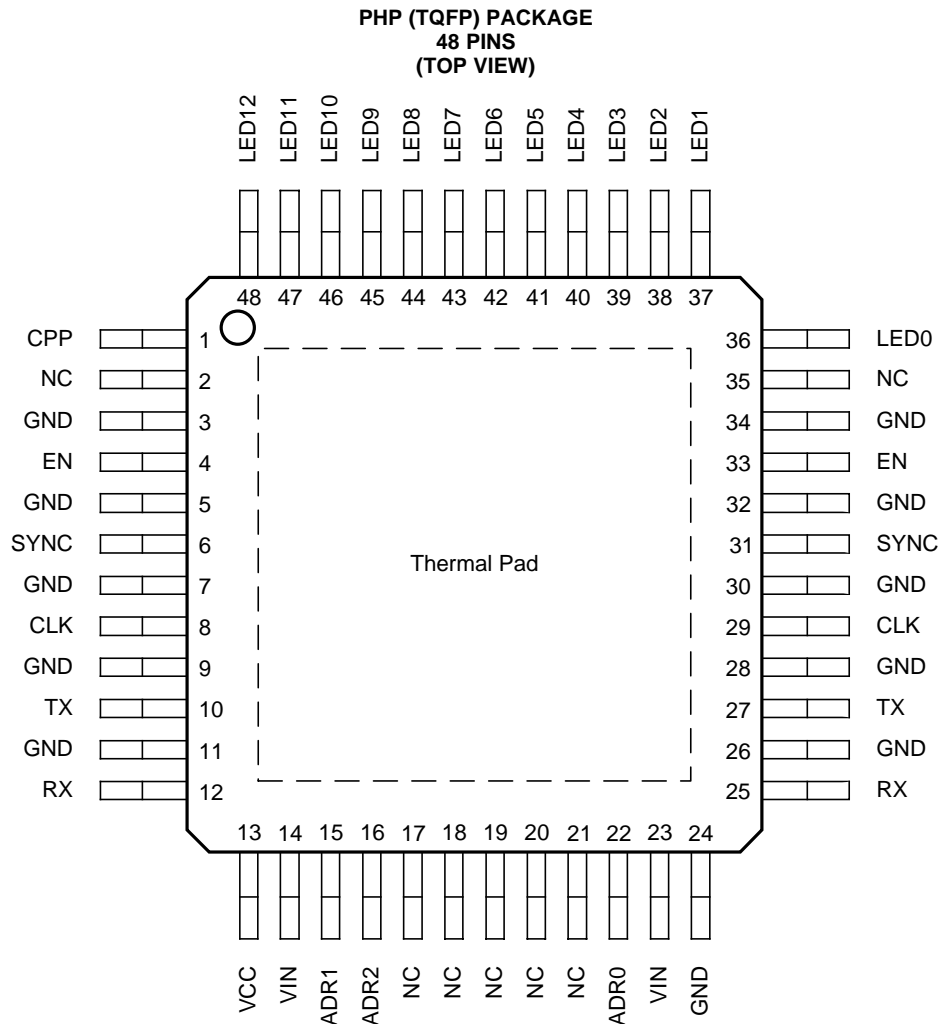

Pin Functions

PIN		I/O	DESCRIPTION
NAME	NO.		
ADR0	22	I	Least significant bit (LSB) of device address. Connect to VIN or GND.
ADR1	15	I	Second bit of device address. Connect to VIN or GND.
ADR2	16	I	Most significant bit (MSB) of device address. Connect to VIN or GND.
CLK	8	I	System clock. This clock is provided externally (by the microcontroller unit or an external oscillator) and is the primary clock for the device.
	29		
CPP	1	I	Charge pump output. Bypass with a ceramic capacitor with a minimum value of 0.1 μ F to LED12.
EN	4	I	Enable pins. The device is active when EN is high or in reset when EN is low. Connect to microcontroller unit output or tie to VCC or VIN for enable at power-up.
	33		
GND	3, 5, 7, 9, 11, 24, 26, 28, 30, 32, 34	—	Device system ground. All pins MUST be connected for proper operation.
LED0	36	O	Connect to cathode of LED1.
LED1	37	O	Connect to anode of LED1 and cathode of LED2.
LED2	38	O	Connect to anode of LED2 and cathode of LED3.

Pin Functions (continued)

PIN		I/O	DESCRIPTION
NAME	NO.		
LED3	39	O	Connect to anode of LED3 and cathode of LED4.
LED4	40	O	Connect to anode of LED4 and cathode of LED5.
LED5	41	O	Connect to anode of LED5 and cathode of LED6.
LED6	42	O	Connect to anode of LED6 and cathode of LED7.
LED7	43	O	Connect to anode of LED7 and cathode of LED8.
LED8	44	O	Connect to anode of LED8 and cathode of LED9.
LED9	45	O	Connect to anode of LED9 and cathode of LED10.
LED10	46	O	Connect to anode of LED10 and cathode of LED11.
LED11	47	O	Connect to anode of LED11 and cathode of LED12.
LED12	48	O	Connect to anode of LED12.
NC	2, 17, 18, 19, 20, 21, 35	—	No connection.
RX	12	I/O	Received data pins. Connect one RX pin of first device to microcontroller unit TX output and use second pin to connect to a RX pin of the second device. All other devices use both pins to route the RX line through each device.
	25		
SYNC	6	I/O	Synchronization pins. Allows synchronization of multiple TPS92661 devices on the same network. May be driven by the microcontroller unit, or one TPS92661 device may be programmed via the serial interface to provide this pulse. Only one device should drive this signal. May be left unconnected if not used.
	31		
TX	10	I/O	Transmitted data pins. Connect one TX pin of first device to microcontroller unit RX input and use second pin to connect to a TX pin of the second device. All other devices use both pins to route the TX line through each device. This pin requires a 100kΩ pull-up resistor.
	27		
VCC	13	O	Output of the on-board 3.3-V LDO. This pin requires a ceramic output capacitor with a value of 0.1 μF or greater. Tie to the VIN pin for 5-V microcontroller unit systems.
VIN	14	I	5-V power supply input for device. Bypass with a ceramic capacitor with a minimum value of 0.1 μF.
	23		
Thermal Pad		-	Connect to system GND.

6 Specifications

6.1 Absolute Maximum Ratings⁽¹⁾⁽²⁾

Over operating free-air temperature range (unless otherwise noted)

		MIN	MAX	UNIT
Input voltage	VIN, VCC to GND	-0.3	7	V
	CPP to GND	-0.3	67	
	CPP to LED12	-0.3	7	
	LEDx to GND	-0.3	60	
	LEDx to LED(x-1)	-0.3	7	
	SYNC, EN, CLK, TX, RX, ADR0-2 to GND	-0.3	7	

- (1) Stresses beyond those listed under *Absolute Maximum Ratings* may cause permanent damage to the device. These are stress ratings only, which do not imply functional operation of the device at these or any other conditions beyond those indicated under *Recommended Operating Conditions*. Exposure to absolute-maximum-rated conditions for extended periods may affect device reliability.
- (2) If Military/Aerospace specified devices are required, contact the Texas Instruments Sales/Office/Distributors for availability and specifications.

6.2 Handling Ratings

			MIN	MAX	UNIT
T _{stg}	Storage temperature range		-40	150	°C
V _(ESD)	Electrostatic discharge	Human body model (HBM), per AEC Q100-002 ⁽¹⁾	-2000	2000	V
		Charged device model (CDM), per AEC Q100-011	-750	750	
		ALL Pins			

(1) AEC Q100-002 indicates HBM stressing is done in accordance with the ANSI/ESDA/JEDEC JS-001 specification.

6.3 Recommended Operating Conditions

over operating free-air temperature range (unless otherwise noted)

			MIN	NOM	MAX	UNIT
V _{IN}	Supply input voltage range		4.5		5.5	V
V _I	Input voltage range per channel	LEDx to LED(x-1)			5.0	V
I _O	Output current range		Thermally Limited			A
f _{CLK}	CLK frequency ⁽¹⁾		0.1		16	MHz
D _{CLK}	CLK duty cycle		40%		60%	
t _{EW}	EN input pulse width low		50			ns
t _{ESS}	EN setup to serial start		24/f _{CLK}			s
t _{SW}	SYNC input pulse width		1/f _{CLK}			s
V _{IH}	High-level input voltage		1.9		V _{VCC} + 0.3 V	V
V _{IL}	Low-level input voltage		GND – 0.3 V		0.8	V
T _A	Ambient temperature		-40		125	°C
T _J	Junction temperature		-40		150	°C

(1) Minimum f_{clk} is applicable only when CKWEN bit is set. f_{clk} down to 0Hz is possible when bit is not set.

6.4 Thermal Information

THERMAL METRIC ⁽¹⁾		TPS92661	UNITS
		TQFP	
		48 pins	
R _{θJA}	Junction-to-ambient thermal resistance	25.7	°C/W
R _{θJC(top)}	Junction-to-case (top) thermal resistance	10.5	
R _{θJB}	Junction-to-board thermal resistance	6.1	
Ψ _{JT}	Junction-to-top characterization parameter	0.2	
Ψ _{JB}	Junction-to-board characterization parameter	6.0	
R _{θJC(bot)}	Junction-to-case (bottom) thermal resistance	0.3	

(1) For more information about traditional and new thermal metrics, see the *IC Package Thermal Metrics* application report, [SPRA953](#).

6.5 Electrical Characteristics

Limits apply over operating junction temperature range $-40^{\circ}\text{C} \leq T_J \leq +150^{\circ}\text{C}$. Typical values represent the most likely parametric norm at $T_J = 25^{\circ}\text{C}$. Unless otherwise noted, $V_{IN} = 5\text{ V}$. For digital outputs, $C_{LOAD} = 20\text{ pF}$.

PARAMETER		CONDITIONS	MIN	TYP	MAX	UNIT
GENERAL						
I_{VIN-OP}	Input operating bias current	No switching		1		mA
V_{IN-UVT}	VIN internal POR threshold	VIN rising			4.5	V
V_{CC-REG}	Regulated VCC voltage	$0\text{ mA} \leq I_{VCC} \leq 5\text{ mA}$	3.1	3.3	3.5	V
$I_{VCC-LIM}$	VCC current limit			10		mA
V_{CPP}	Charge pump operating voltage	$V_{VIN} = 5\text{ V}, V_{SW} = 0\text{ V} - 60\text{ V}$		6.2		V
f_{CPP}	Charge pump oscillator frequency		1.3	2.3	3.3	MHz
LED MATRIX SWITCHES						
$R_{DS(on)}$	LED switch on-resistance ⁽¹⁾			225		mΩ
$R_{ALL(on)}$	All switches on-resistance	Measured LED12 - LED0		1800	3400	mΩ
$I_{DS(off)}$	OFF state switch leakage current				50	μA
V_{TH-S}	LED short threshold voltage	$V_{SW} = 0\text{ V} - 60\text{ V}$	0.52		1.4	V
V_{TH-O}	LED OPEN threshold voltage	$V_{SW} = 0\text{ V} - 60\text{ V}$	5	6	6.9	V
t_{TO-O}	LED OPEN detection and correction delay			50	150	ns
t_{REP}	LED fault reporting delay				5	μs
$t_{RISE(LEDx)}$	LEDx drain voltage rise time ⁽²⁾	$I_{LED} = 800\text{ mA}$		2		μs
$t_{FALL(LEDx)}$	LEDx drain voltage fall time ⁽²⁾	$I_{LED} = 800\text{ mA}$		2		μs
DIGITAL SPECIFICATIONS						
V_{IH-TH}	High-level input voltage threshold				1.9	V
V_{IL-TH}	Low-level input voltage threshold		0.8			V
V_{OH}	High-level output voltage	$I_{SOURCE} = 2\text{ mA}, V_{VCC} = 4.0\text{ V}$	4.27			V
V_{OL}	Low-level output voltage	$I_{SINK} = 2\text{ mA}, V_{VCC} = 4.5\text{ V}$			0.23	V
I_{OS}	Output short circuit current (source or sink)	$V_{VCC} = 4.5\text{ V}$		42		mA
R_{SP}	Internal SYNC pull-down			100		kΩ
t_{WD-TO}	CLK watchdog timeout			$32/f_{CPP}$		μs
t_{TO}	CLK rise to TX output valid ⁽²⁾			80		ns
t_{TZ}	CLK rise to TX output tri-state ⁽²⁾			80		ns

(1) Single channel on-resistance ($R_{DS(on)}$) measurement includes internal bond wires. All switches on-resistance ($R_{ALL(on)}$) should be used for all power calculations. See [Internal Switch Resistance](#) for details.

(2) Specified by design. Not production tested.

6.6 Typical Characteristics

$T_A = 25^\circ\text{C}$ free air unless otherwise specified

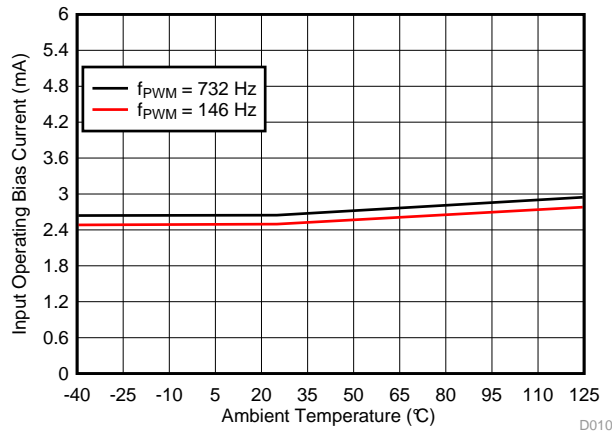

$V_{VIN} = 5.5\text{ V}$ $f_{CLK} = 6\text{ MHz}$
Figure 1. Input Voltage Current vs Temperature

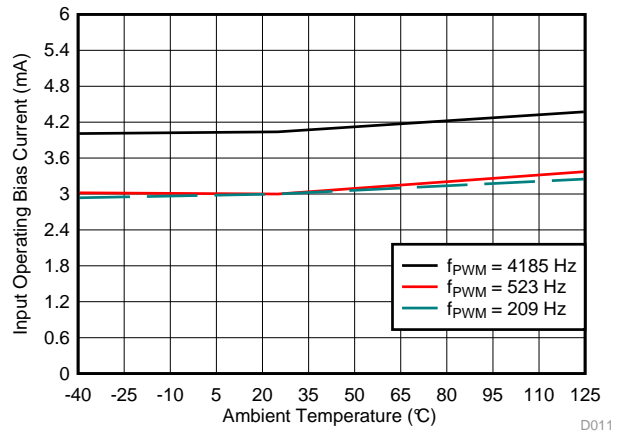

$V_{VIN} = 5.5\text{ V}$ $f_{CLK} = 8.57\text{ MHz}$
Figure 2. Input Voltage Current Draw vs Temperature

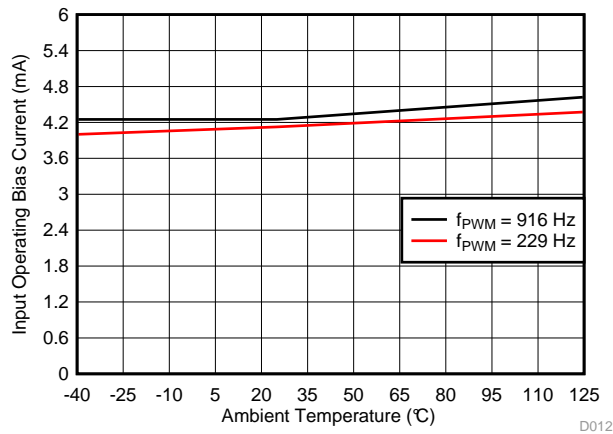

$V_{VIN} = 5.5\text{ V}$ $f_{CLK} = 15\text{ MHz}$
Figure 3. Input Voltage Current Draw vs Temperature

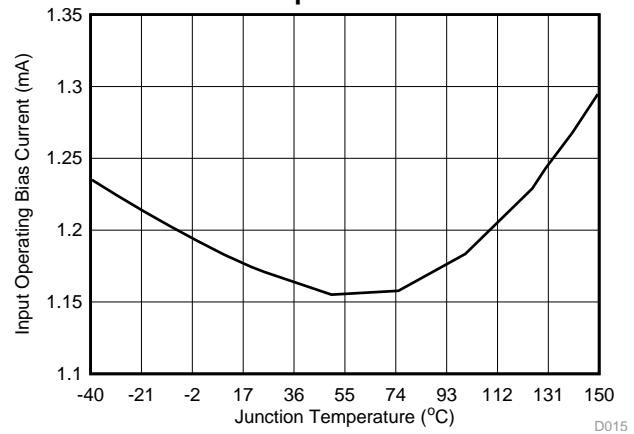

Figure 4. Input Operating Bias Current, Non-Switching vs. Junction Temperature

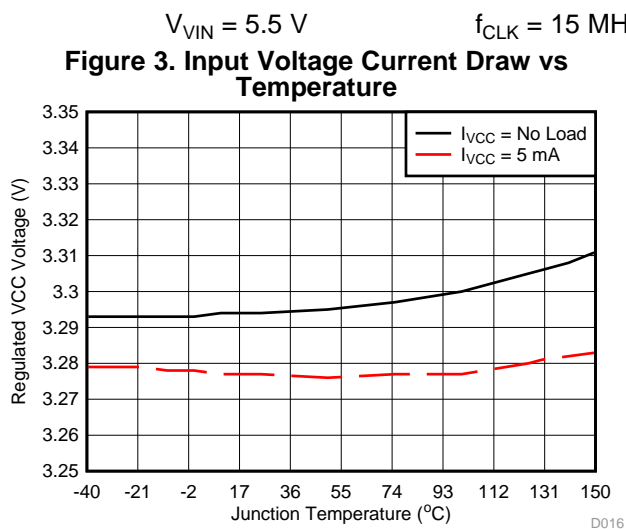

Figure 5. Regulated VCC Voltage vs Junction Temperature

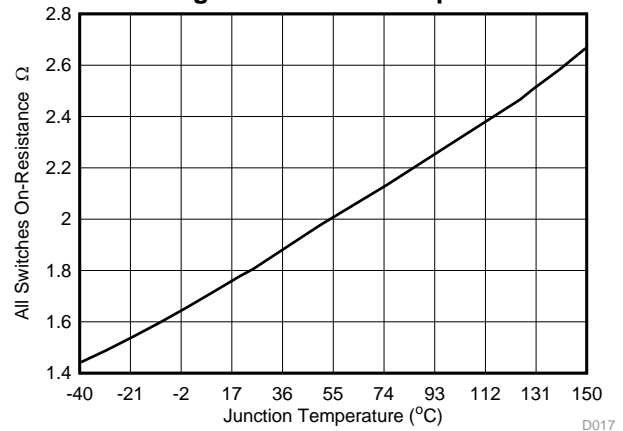

Figure 6. All Switches On-Resistance vs Junction Temperature

Typical Characteristics (continued)

T_A = 25°C free air unless otherwise specified

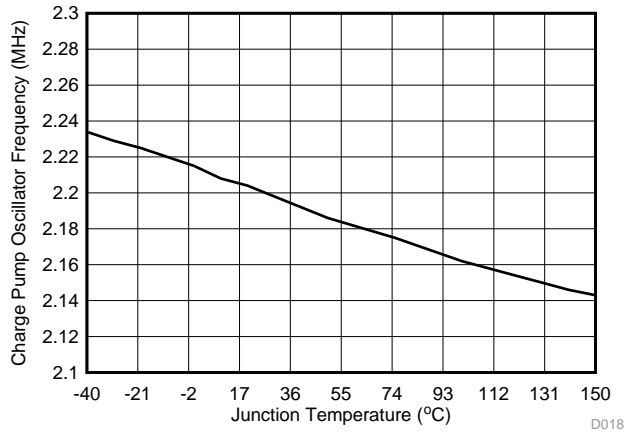

Figure 7. Charge Pump Oscillator Frequency vs Junction Temperature

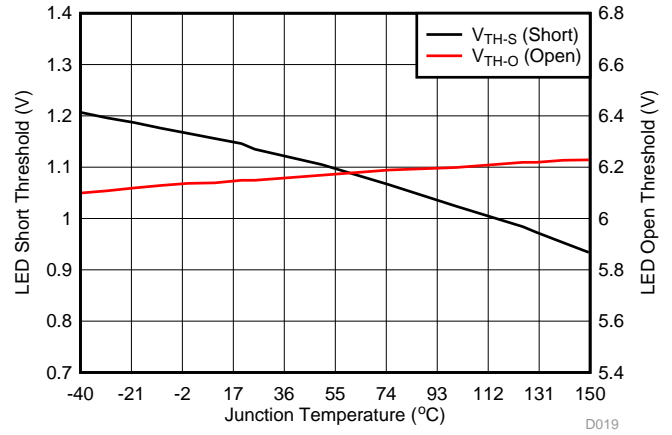

Figure 8. Channel Open and Short Protection Thresholds vs Junction Temperature

7 Detailed Description

7.1 Overview

The TPS92661 lighting matrix manager (LMM) device, in conjunction with a buck switching current regulator, enables a fully dynamic matrix beam solution where each LED can be individually controlled. This type of control of an LED array is ideally suited for dynamic headlight applications where adaptive beam forming requires pixel level control of the array.

The TPS92661 device configures 12 series connected low voltage switches (MOSFETs) that can float up to 67 V above ground potential. Each switch connects in parallel to one LED, thereby creating individual shunt paths across each LED of a series string of 12 LEDs. LED strings with fewer LEDs can be used, however the unused channels should be physically shorted externally to reduce unnecessary internal power consumption.

Each switch has an individual driver, overvoltage protection circuit and diagnostics circuit referenced to the source of that switch. This configuration allows for fully dynamic operation with the switches above it and below it. The device monitors overvoltage conditions on each switch and automatically protects them in the event of an open LED connection. The device detects open LED conditions as well as shorted LED conditions and reports them through the fault reporting network.

All twelve internal bypass switches can be individually pulse width modulated (PWM) at a programmed frequency and duty cycle. This PWM dimming topology provides Inherent phase shifting capability. In addition, the switch transitions during PWM dimming are slew rate limited to mitigate any EMI concerns due to the di/dt and dv/dt of the switching action.

The TPS92661 device also provides multi-drop UART communications capability between a host MCU and up to 8 slave TPS92661 devices. The UART receives data corresponding to the desired PWM information for all 12 internal switches. In addition, it can send back fault and other diagnostic data to the host MCU. Hardware connections on the three address pins allows addressing of the eight devices.

An internal regulator accepts the 5-V power supply input for the TPS92661 device and generates a 3.3-V regulated output for the I/O buffers used in the internal UART. The internal regulator can be bypassed by shorting VIN to VCC if 5-V communication is desired.

The combination of features in the TPS92661 device provides the ideal interface for individual control of high current LED arrays. The [Figure 27](#) shows a dynamic headlight application using multiple TPS92661 devices. The electronic control unit (ECU), usually attached to the outside of the headlight, contains the master MCU, a boost pre-regulator stage that takes the variable battery voltage and steps it up to a stable DC voltage rail. The application includes multiple channels of buck current regulators to provide a stable current through each series string of 12 high brightness LEDs. The TPS92661 device should reside on the LED load board where it is as close as possible to the LEDs to which it directly connects.

This location has two major benefits.

- The close proximity minimizes distributed inductance and parasitic capacitance associated with the cable connection between ECU board and LED load board. When PWM dimming with a parallel shunt FET, locating the switch close to the LED prevents large ringing during each transition.
- The close proximity offers better thermal connection

Ultimately, the TPS92661 device enables an optimal partition for a flexible, high performing dynamic headlight system.

7.2 Functional Block Diagram

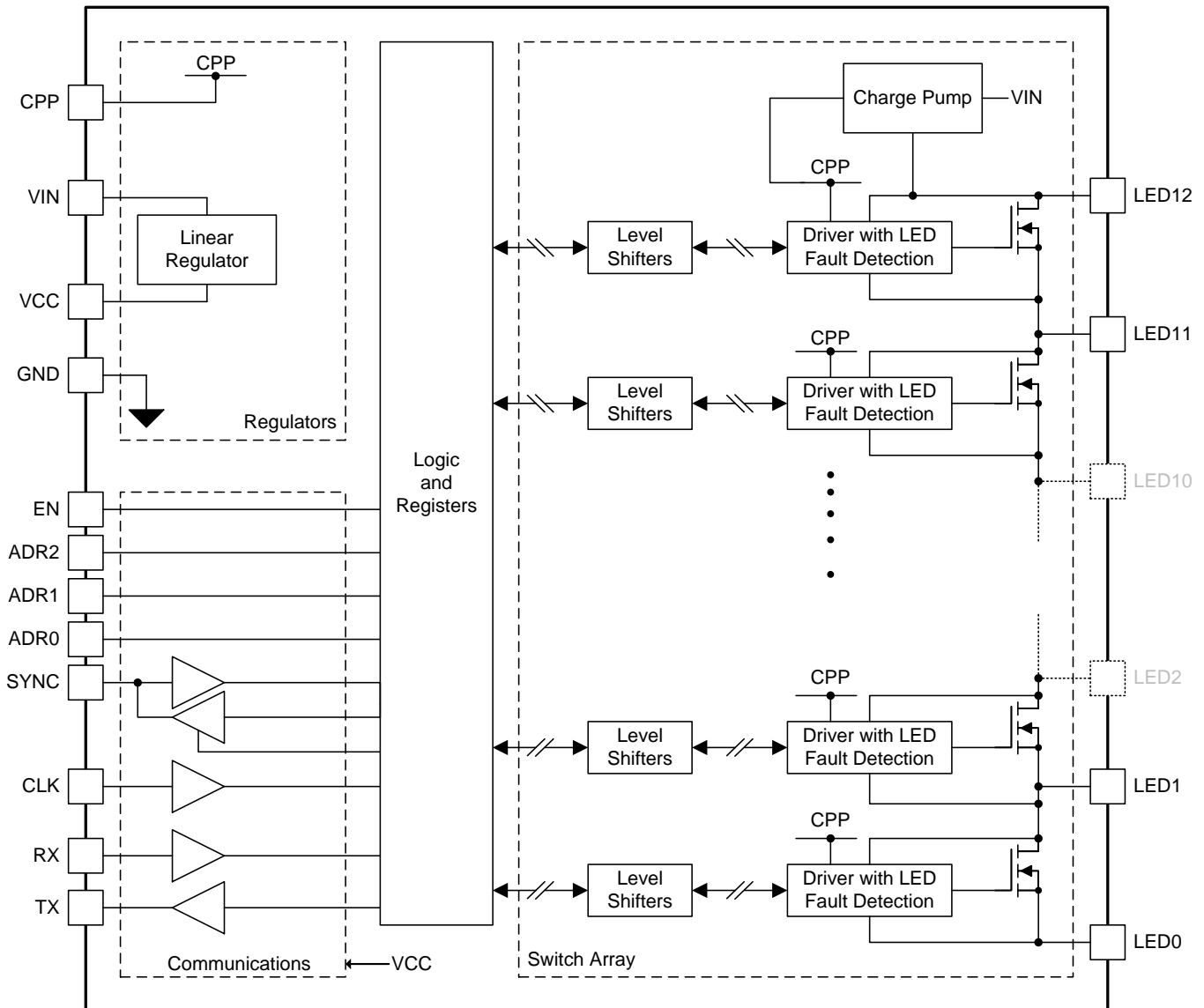

7.3 Feature Description

7.3.1 Controlling the Internal LED Bypass Switches

The TPS92661 device (LED Matrix Manager) consists of 12 series connected bypass switches between terminals LED12 and LED0. Each bypass switch, when driven to an off state, allows the string current to flow through the corresponding parallel-connected LED, turning the LED on. Conversely, driving the bypass switch to an on state shunts the current through the bypass switch and turns the LED off.

Feature Description (continued)

7.3.2 Internal Switch Resistance

Each single switch (connected between LED_n and LED_{n-1}) has a measurable typical R_{DS(on)} value of 225 mΩ. This measurement includes the actual on-resistance (R_{DS(on)}) of the switch and the resistance of the two internally connected bond wires. When multiple series switches are on, the effective resistance is not simply the number of channels multiplied by 225 mΩ because there are not two conducting bond wires for every series-connected switch. For this reason the all-switches on-resistance (R_{ALL(on)}) is specified in the [Electrical Characteristics](#) table. This value includes the twelve R_{DS(on)} on-resistances and the resistance of the bond wires at each end of the series connected switches.

The dominant power loss mechanism in the TPS92661 device, is I²R loss through the switches. Other power loss sources are always less than 50 mW. When calculating the power dissipation of the TPS92661 device switches, use [Equation 1](#) for the best estimation of this power loss.

$$R_{DS(on)}(x_channels) = R_{ALL(on)}(max) \times \left(\frac{n}{12} \right) = 238 \text{ m}\Omega \times n$$

where

- n is the number of channels

(1)

See the [6 LED, 1.5-A Application](#) section for a sample calculation.

7.3.3 PWM Dimming

The TPS92661 device provides 10-bit PWM dimming of each individual LED. The LED turn-on and turn-off times are separately programmed for each LED. The LEDxON registers and LEDxOFF registers (where x = 1 to 12) determine the LED turn-on and turn-off times, respectively, within the PWM dimming period. Phase shifting can be accomplished by staggering the LEDxON times or LEDxOFF times. The 10-bit internal PWM Period Counter (TCNT) is compared against the LEDxON and LEDxOFF values.

When TCNT reaches the programmed LEDxON value for a given LED, the corresponding bypass switch is turned off to force current through the LED. Similarly, when TCNT reaches the programmed LEDxOFF value, the bypass switch is turned on to turn off the LED. TCNT counts continuously from 0 to 1023 and returns to 0 again. The LED PWM dimming period equals 1024 times the internally divided, programmable PWM clock period. [Figure 9](#) shows an example of LED PWM using values of LEDxON = 250 and LEDxOFF = 800.

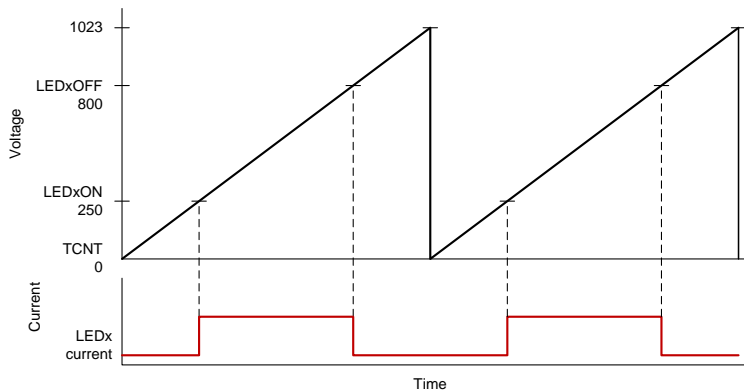

Figure 9. LED PWM Example

Because the LEDxON and LEDxOFF times are completely programmable, this allows the system flexibility to phase shift the leading edge (LED On), the trailing edge (LED Off), or double-edge PWM.

The comparison circuitry consists of a digital comparator, along with an AND gate to allow that particular comparison to propagate to the LED switch. The TCNT counter value is continuously compared against the value programmed into the LED On/Off registers. The ENON bit that corresponds to that particular LED determines whether or not that comparison has any effect at the LED. The logic is represented in [Figure 10](#).

Feature Description (continued)

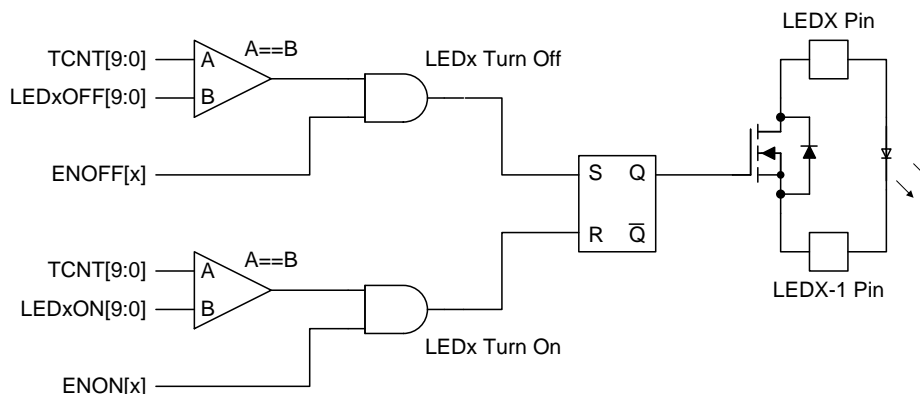

Figure 10. PWM Dimming Control Logic

7.3.4 PWM Clock

The PWM clock that drives TCNT is a divided-down version of the CLK input. The divider is programmed by writing to the PWM clock divider register (PCKDIV). The divider comprises two dividers in series: a power-of-2 clock divider followed by a decimal count divider (see [Figure 11](#) and [PWM Clock Divider Register \(PCKDIV\)](#) for PCKDIV bitmap). Upon power-up, the PWM clock divider is programmed to a divisor value of 16.

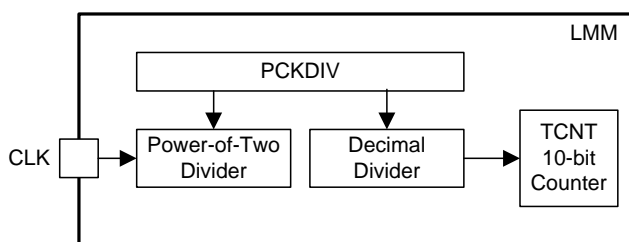

Figure 11. PWM Clock Divider

7.3.5 PWM Synchronization

Upon power-up, the TCNT counter is reset to 0. The TCNT counter is clocked by the internal PWM clock. In order to correctly synchronize multiple TPS92661 devices on the same network, two conditions must be met:

- All TPS92661 devices must be clocked by the same clock on the CLK terminal.
- All TPS92661 devices must be programmed with the same PWM clock dividers (PCKDIV).

Assuming that these conditions are met, the TPS92661 devices may be synchronized by either of two methods:

1. As shown in [Figure 12](#), the TPS92661 device includes a synchronization input/output (SYNC) and a synchronization master bit (SCMAST) in the system configuration register (SYSCFG). If SCMAST is set to 1, the TPS92661 device drives the SYNC terminal. The TPS92661 device generates a high pulse that is one-half of a PWM period on SYNC when TCNT and the PWM clock divider are about to roll over to 0. This SYNC signal can be fed to other TPS92661 devices. In other words, either the MCU can drive SYNC, or only one TPS92661 device should have SCMAST set to 1. The rest of the TPS92661 devices on the network must have SCMAST set to 0. If SCMAST is set to 0 (the default value), a low-to-high transition on SYNC at least one CLK cycle resets both TCNT and the PWM clock divider to 0 after internally synchronizing to the rising edge of CLK. SYNC is a feed-through signal that may be tied to the next TPS92661 device in order to synchronize multiple TPS92661 devices with respect to each other.

NOTE

In order to prevent bus contention, ensure that the network design includes only one synchronization master.

Feature Description (continued)

- The TCNT counter and PWM clock divider can both be reset to 0 at any time by issuing a broadcast write synchronization command. Due to UART bit sampling variability, the synchronization is guaranteed to be within only 16 CLK cycles between TPS92661 devices.

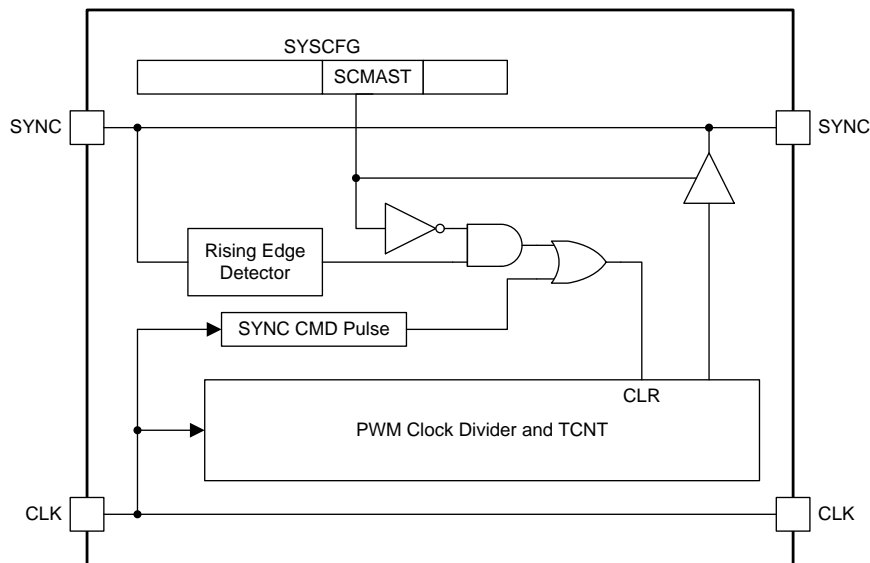
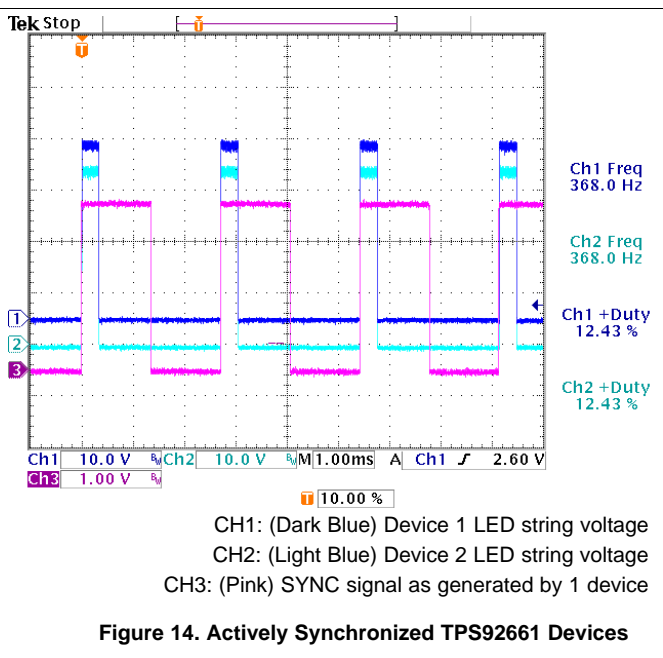
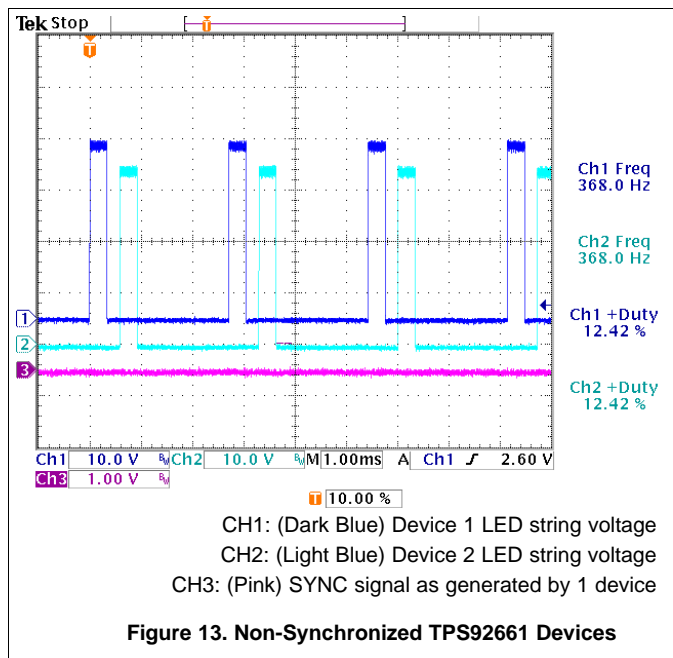

Figure 12. PWM Synchronization

Figure 13 and Figure 14 show an example of two non-synchronized TPS92661 devices and two synchronized devices respectively. In this example all twelve channels on each device are programmed with LED_{ON} = 0 and LED_{OFF} = 128. In the non-synchronized example TCNT = 0 occurs at two different places in time. By using the SYNC function, TCNT = 0 occurs simultaneously for both devices.



Feature Description (continued)

7.3.6 Switch Slew Control

The gate drive control of each series switch slows the rate of change of current through the device. This control eases EMI requirements and aids in the system operation. The switching transition controls the current through the switch at each edge to approximately 800 mA/2 μ s. The internal circuitry of the device controls the slew rate. The user cannot change the slew rate. The rise and fall slew rates are matched to ensure accurate representation of the PWM duty cycle. These slew rates assume no LED string capacitance.

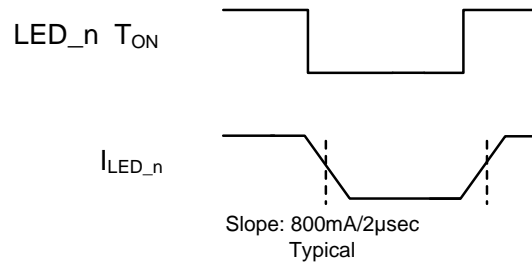
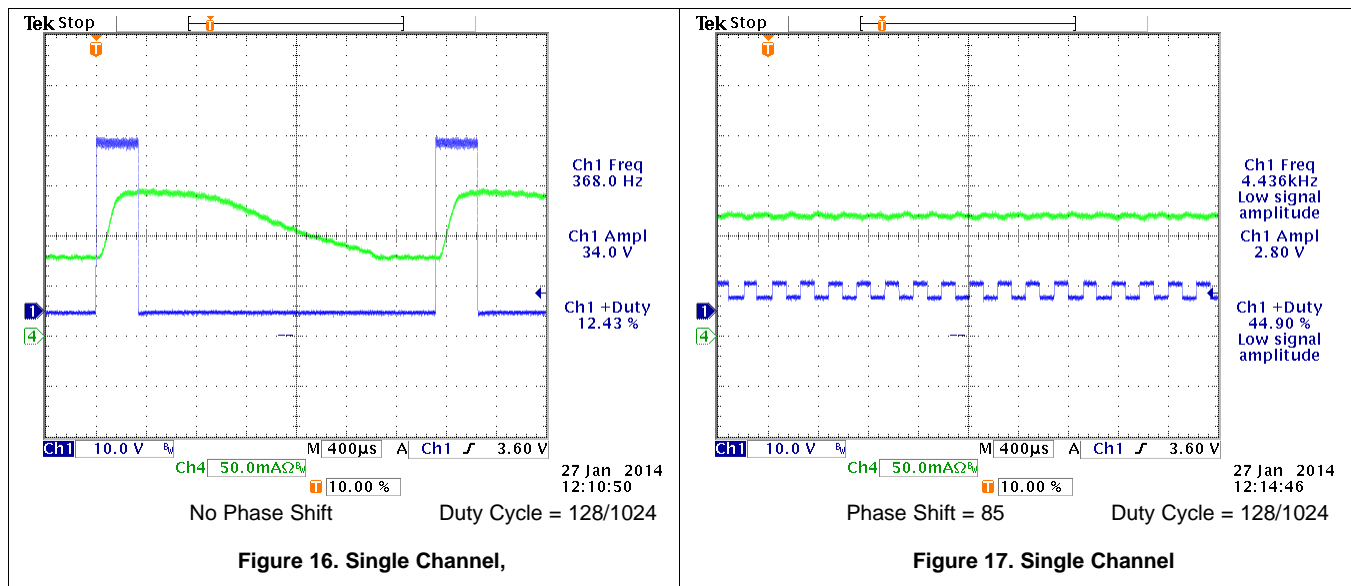

Figure 15. TPS92661 Slew Rate Control

7.3.7 Effect of Phase Shifting LED Duty Cycles

Figure 16 and Figure 17 show the effective system input current (CH4, green trace) and $V_{(LED12-LED0)}$ string voltage (CH1, blue trace) for various phase shift settings. The results illustrate the advantages of adjusting the phase shift value to minimize the variation in input current. Figure 16 illustrates a zero phase shift condition by setting all twelve LEDxON values to zero and all twelve LEDxOFF values to 128. Figure 17 illustrates optimal phase shifting where all twelve LEDxON values are spaced by a count of 85 (0, 85, 170, 235, ...). The input current variation is greatly reduced with optimal phase shifting as all twelve channels do not draw current from the input simultaneously. This reduces demands on the energy storage capacitance at the system input.



7.3.8 LED Fault Detection and Protection

Each individual bypass switch is driven by a floating driver which is powered by the charge pump (see [Functional Block Diagram](#)). The steady floating driver supply also enables continuous protection and monitoring of LED open and short events.

Feature Description (continued)

In the event of an OPEN LED failure, an internal comparator monitors the drain-to-source voltage of the internal switch. If the voltage exceeds V_{TH-O} (typical 6 V) the device overrides the switch-off signal and turns on the switch. This action maintains current flow in the rest of the LED string in the presence of a faulty or damaged LED and protects the internal switch. The internal latch holds this state until a subsequent on and off cycle at which time the switch attempts to turn off again, and the condition is re-evaluated. The protection circuit also sets the corresponding bit in the FAULT register described in the *Diagnostic Registers* section. The controller can poll this register to determine whether a fault has occurred.

When the device resets a FAULT bit in the register array by writing the bit back to zero, it then clears the latch and re-enables the OPEN switching transition of the corresponding LED. This feature allows the controller to perform multiple checks of the LED fault so that false LED faults can be filtered via software.

Similar to LED open detection, an LED short is detected via monitoring the drain-to-source voltage of the internal switch. If the voltage does not exceed the V_{TH-S} threshold by the end of the PWM cycle, the same fault register bit is set. Both short and open cases are handled by the same register as each case has the equivalent outcome, which is that the channel is bypassed. (see [Figure 18](#))

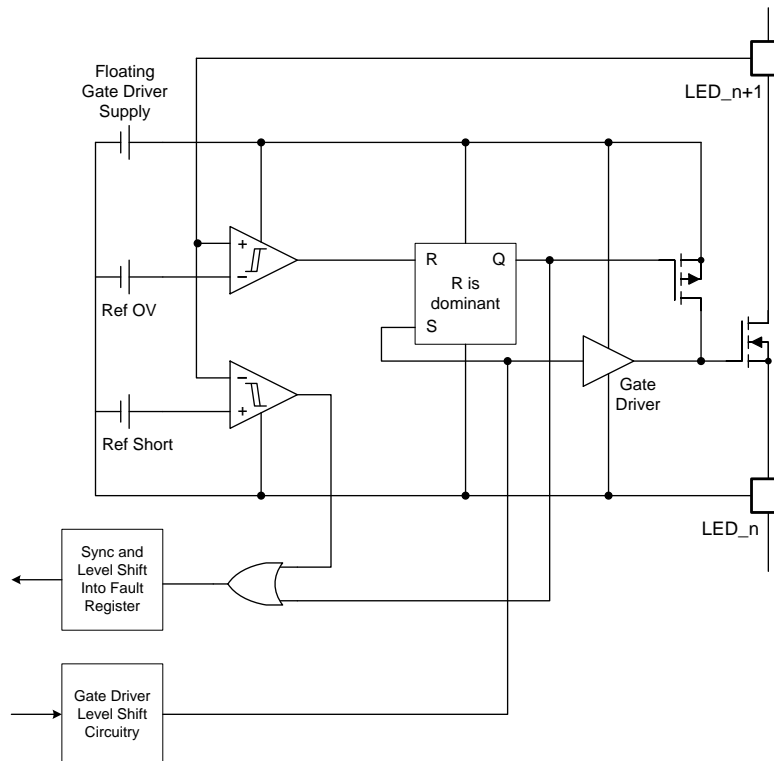

Figure 18. Fault Detection Block

Feature Description (continued)

7.3.8.1 Fault Reporting and Timing

Fault detection and protection occur immediately and are independent of any internal clock. The device detects an overvoltage condition when the channel voltage rises to the OVP (overvoltage protection) comparator threshold. The channel switch is then latched ON with a delay of approximately 50 ns (typical). This detection generates a fault signal that is sent to the internal fault register when TCNT = LEDxOFF where it can be polled by the user. Similarly, the short detection fault signal is sent with the same timing. The [Diagnostic Registers](#) are updated in a maximum time of one full PWM period (a PWM count of 1024). Due to internal propagation delays the LED On-time count must conform to [Equation 2](#) for accurate fault reporting. For typical applications this may require fault reporting to be ignored at duty cycles less than 1%.

$$\text{LEDn}_{\text{ON_TIME_COUNT}} \geq \left(\frac{(t_{\text{RISE}} + t_{\text{REP}})}{\text{PCKDIV}} \times f_{\text{CLK}} \right) + 4 \quad (2)$$

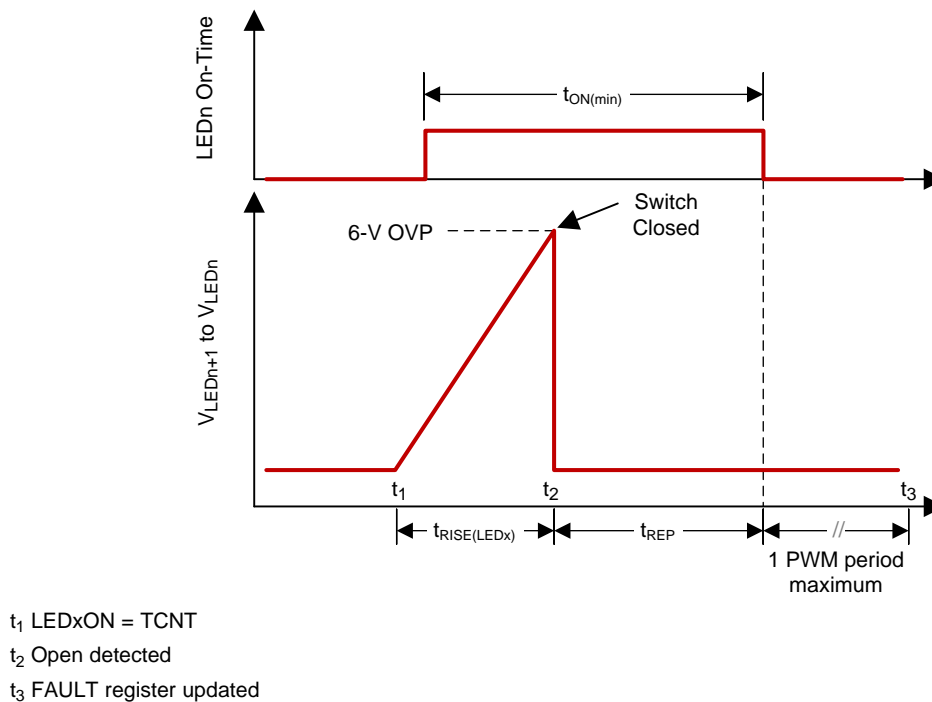

Figure 19. LED Open Fault Detect Timing

7.3.8.1.1 LED Open Fault Detect Timing Example

In an LED open event, 12 LEDs are being turned on sequentially, creating the staircase waveform as shown in [Figure 20](#). At approximately time = 280 μ s, LED6 is commanded to turn on but it is open. The TPS92661 device fault circuit immediately clamps the node by turning the channel switch ON. As the LEDs in the string are turned off, the previously open LED remains shorted for that cycle as the system has detected the fault and forced the switch to stay on. Other channels continue to operate normally.

Feature Description (continued)

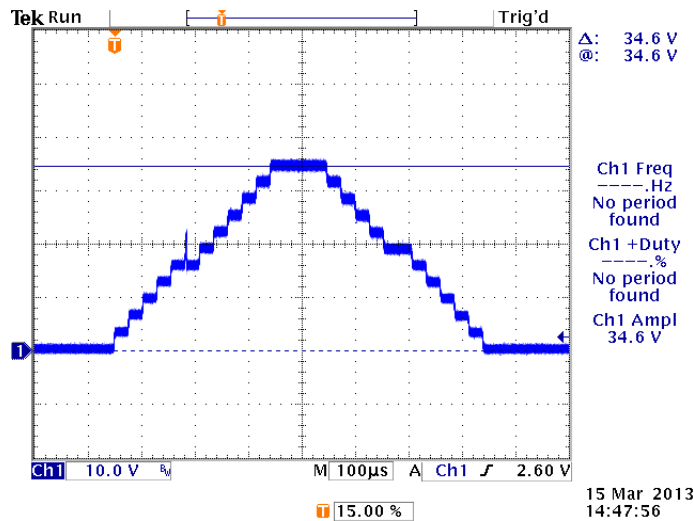

Figure 20. LED Open Detection and Protection

7.3.9 Glitch-Free Operation

To help eliminate glitches in the LED current during register updates, the TPS92661 device implements the atomic multi-byte writes function and the synchronous updates function.

7.3.9.1 Atomic Multi-Byte Writes

Because the LEDxON and LEDxOFF registers are 10-bits wide and span across multiple bytes, there is a chance that during the time between the serial transmission of the lower eight bits and the upper two bits the resulting register value is wrong. To overcome this problem, the communications protocol provides for atomic multi-byte writes. This function updates all of the desired registers at one time, only after receiving an entire transaction frame. For example, only after the entire nine-byte transaction frame has been successfully received, does the device issue a write command to registers 00H-04H (which represent the LED1ON, LED2ON, LED3ON and LED4ON registers) and transfers it to the final registers. This transfer has the additional benefit of updating the final registers only if the cyclical redundancy check (CRC) for the transaction frame is correct.

7.3.9.2 Synchronous Updates

Serial communications are asynchronous to the TCNT period. The device can write LEDxON and LEDxOFF with any value from 0x000 to 0x3FF at any time within the TCNT period. Consider a situation where there are no timing restrictions on updating the final registers. When the device receives a new LEDxOFF value while the corresponding LED is on and TCNT is already greater than the new LEDxOFF value, the LED remains on until it reaches the LEDxOFF value in the next TCNT period. This can appear as a glitch in LED light output.

To overcome this issue, the device writes a new value LEDxOFF and stores it in a temporary register. The device updates the final register only after TCNT reaches the next LEDxON register value. The converse is true for write commands to a particular LEDxON. In that case, the device updates the final register only after TCNT reaches the next LEDxOFF value. This sequence allows the device to update the LEDxOFF registers at the corresponding LED turn-on time and update the LEDxON registers at the corresponding LED turn-off time.

When LEDxON and LEDxOFF are both set to the same value, the device interprets the setting as an LED off condition. This is equivalent to clearing the ENON bit for that particular LED. The next time TCNT reaches the common LEDxON and LEDxOFF value, the device ignores LEDxON and the LED turns off (if it was on) and remains off until the device writes LEDxON and/or LEDxOFF and updates them with different value(s). More specifically, the LEDOFF comparison takes precedence over the LEDON comparison. Figure 21 illustrates an update example. Case (1) shows the resulting single PWM cycle on time that would occur if the writing of the registers were not handled through a temporary register. Case (2) shows the functionality of the TPS92661, where the register update is controlled, eliminating a false conduction cycle.

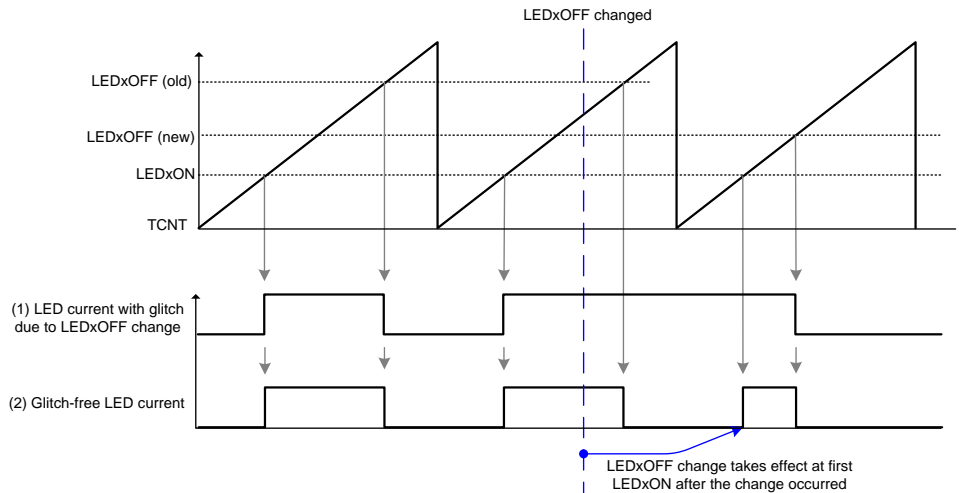
Feature Description (continued)

Figure 21. Glitch-Free LED Dimming Operation
7.3.9.2.1 LEDxON = LEDxOFF Boundary Condition

The synchronous update method removes a large majority of glitches that could be caused in the light output, but one case should be considered. The reason is based on the synchronous update technique and can occur when reducing the PWM duty cycle to zero. If the duty cycle is controlled by the LEDxOFF time, the LEDxON count is fixed each cycle. To dim, the LEDxOFF count will be gradually reduced. Because of the way the LEDx ON/OFF updates occur, a glitch can occur at the point when LEDxON = LEDxOFF causing the LED to remain on for a single cycle. The recommended method to turn a channel fully off is to avoid the implementation of LEDxON = LEDxOFF and use the corresponding ENON bit in the [Enable Register](#) for that channel. For example, to dim a given channel to zero duty cycle: LEDxOFF reduces to LEDxON+1, then sets that channel's ENON bit to 0.

7.3.10 Internal Oscillator and Watchdog Timers

The TPS92661 device includes two watchdog timers: a [Clock Watchdog Timer](#) and a [Communications Watchdog Timer](#). The clock watchdog timer operates using a free-running internal oscillator. The communications watchdog timer operates using the incoming CLK signal. Both watchdog timers only operate when enabled after power-up by writing their respective enable bits to a 1 in the SYSCFG register (CKWEN for the clock watchdog timer and CMWEN for the communications watchdog timer). The Default LED State Register (DEFLED) determines which state the LEDs are placed in during a watchdog timeout period. (see the [Default LED State Register \(DEFLED\)](#) section for details.

The [Figure 22](#) shows the subsequent state flow after a watchdog timer limit is reached.

Feature Description (continued)

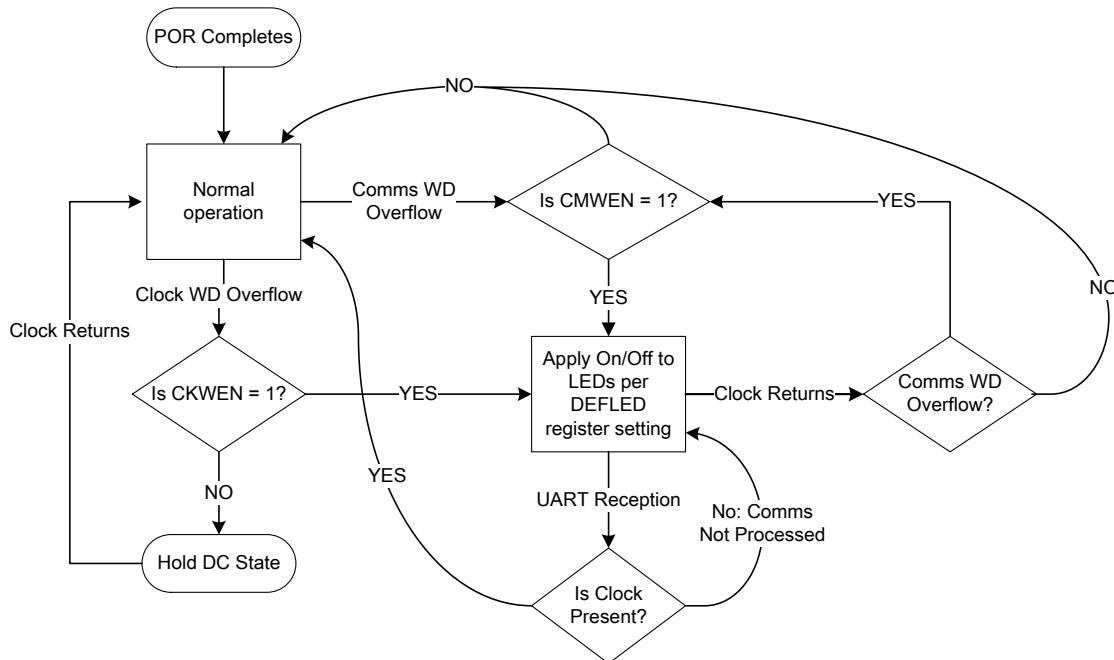

Figure 22. Watchdog Timer Overflow Flow Chart

7.3.10.1 Clock Watchdog Timer

If the external CLK input stops toggling for 32 internal oscillator cycles (approximately 14 μ s, typical) the clock watchdog timer times out and all of the LEDs are turned on or off according to the programmed values in the DEFLED register. They remain in that state until CLK begins toggling again. During this time, the device does not receive or transmit UART communications. The device does not reset the internal registers in the event of clock loss, and the LEDs begin turning on and off according to their LEDxON/LEDxOFF register settings only when the clock returns. If the clock watchdog timer is not enabled the TPS92661 is capable of operating at frequencies down to 0 Hz.

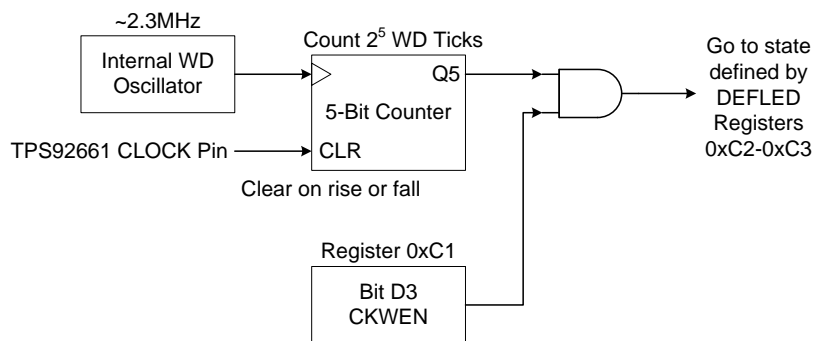

Figure 23. Clock Watchdog Timer Logic

7.3.10.2 Communications Watchdog Timer

Similarly, if the CLK remains running but the device receives no transaction with a correct CRC for a period of 2²² CLK cycles, the communications watchdog timer times out and the device sets the LEDs to the state defined in the DEFLED register. Only after a valid UART command has been received with a correct CRC do normal PWM duty cycles resume on the LED outputs.

Feature Description (continued)

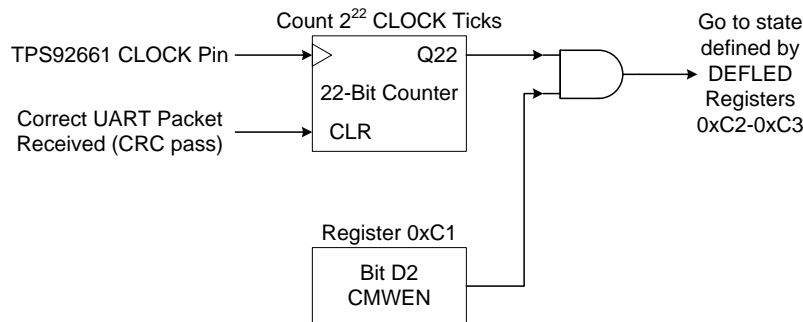

Figure 24. Communications Watchdog Timer Logic

7.4 Device Functional Modes

The TPS92661 device may be configured and controlled using a MCU connected via a standard serial UART. Up to eight devices may be connected to the same UART to form a network.

7.4.1 Digital Interface Connections

7.4.1.1 Address (*ADR0*, *ADR1*, and *ADR2* Pins)

The address pins should be tied to VIN or GND to set the address of the TPS92661. **Up to eight TPS92661s can exist on the same network.** See [Table 2](#) for a summary of device address configurations.

7.4.1.2 Clock (*CLK* Pin)

The CLK pin is the input for the primary system clock. It serves as the time basis for both the UART, as well as the LED PWM hardware. The device functions with a clock input as high as 16 MHz. The clock rate should be selected based on the desired UART bit rate. CLOCK can be provided by the PWM peripheral of the master microcontroller, or by a local oscillator. All TPS92661s on the same network should share the same clock.

7.4.1.3 Internal Charge Pump (*CPP* Pin)

The CPP pin functions as the output of the internal charge pump. The device uses the charge pump voltage as the gate drive voltage for the internal floating switches. Bypass the CPP pin to the LED12 pin with a capacitor with a value of at least 0.1 μ F.

7.4.1.4 Enable (*EN* Pin)

The ENABLE pin is an active-high enable signal for the TPS92661 device. When driven low, it resets all internal switches, state machines, and registers to their default states. The reset state of the switches is closed, and registers are reset (see [Table 7](#)). The managing microcontroller can actively drive this pin. Alternatively tie this pin to VCC or VIN to enable the device at power-up. The EN pin input has internal protections against charge injection and requires no series resistor when tied to one of the local power rails.

7.4.1.5 GND Pin

Proper operation of the TPS92661 device requires that all GND pins **MUST** be tied to system ground.

7.4.1.6 Receive (*RX* Pin)

The RX pin is the TPS92661 UART input. It should be connected to the UART Tx pin of the MCU, as well as the other TPS92661 RX pins on the network. The bit rate of data transmitted on this pin should be at $\text{CLOCK} / 16$, and is fixed at that bit rate.

Device Functional Modes (continued)

7.4.1.7 Synchronization (SYNC Pin)

The SYNC pin synchronizes the internal PWM counter of the TPS92661 device. At reset, the SYNC pin acts as an input, and a low-to-high pulse on this pin resets the TCNT register to 0x000. When an external microcontroller drives this pin, the pulse should be generated at the LED PWM frequency. To calculate this frequency, use Equation 3.

$$f_{\text{PWM}} = \text{CLOCK} / \text{Programmed Divisor} / 1024 \quad (3)$$

Writing a '1' to the SCMAST bit in the SYSCFG register programs the SYNC pin to function as an output. Establish only one TPS92661 device as the master if the application requires this output configuration. To prevent contention on the SYNC line configure only one SYNC master (driver) in the system at a time. The SYNC pin is internally pulled down and can remain unconnected if it is not used.

7.4.1.8 Transmit (TX Pin)

The TX pin is the UART output of the TPS92661 device. Connected the TX pin to the microcontroller UART RX pin. The bit rate of data transmitted on this pin is $f_{\text{CLK}}/16$, and is fixed at that bit rate. Connect all TX pins on each TPS92661 device that are on the same network. Connect a single, 100-kΩ pull-up resistor from TX to VCC. Because the TX pin is a tri-state output, an external pull-up resistor is required to avoid triggering false start conditions at the microcontroller UART.

7.4.1.9 Primary Power Supply (VIN Pin)

The VIN pin is the primary power supply input for the TPS92661 device. Connect the VIN pin to a nominally 5-V supply, and include a bypass capacitor nearby with a value of at least 0.1-μF.

7.4.1.10 On-Board 3.3-V Supply (VCC Pin)

The VCC pin is the input for the positive rail of the internal digital I/Os. See the [Internal Regulator](#) section for configuration guidelines.

7.4.2 Internal Pin-to-Pin Resistance

There are pin pairs for each digital I/O on the TPS92661 device. This allows for easy routing between multiple devices on a single sided PCB. To help estimate the voltage drop across the pin-to-pin connection, see Figure 26.

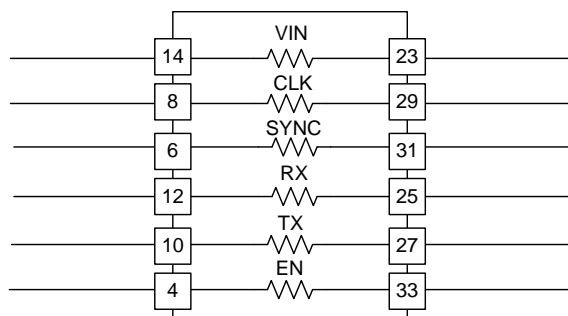

Figure 25. Pin-to-Pin Internal Resistance

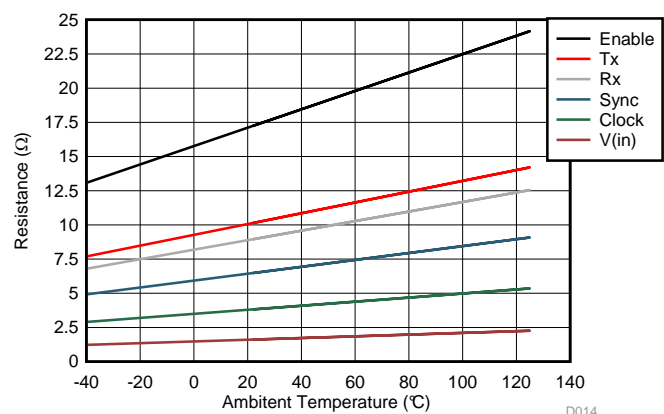

Figure 26. Pin-to-Pin Cross-Device Resistance

7.4.3 UART Physical Layer

The microcontroller unit UART communicates with the TPS92661 device using serial TTL signaling. The TX and RX lines are connected to the TPS92661 device as shown in Figure 27. The pairs of TX and RX pins on the TPS92661 device are feed-through pins, and either pin may be used to connect the TPS92661 device to the network.

Device Functional Modes (continued)

A tri-state buffer drives the TX output. In order to prevent false START bit detection by the microcontroller unit when a TPS92661 device releases the bus, place an external, 100-kΩ pull-up resistor on the RX input return line of the microcontroller unit.

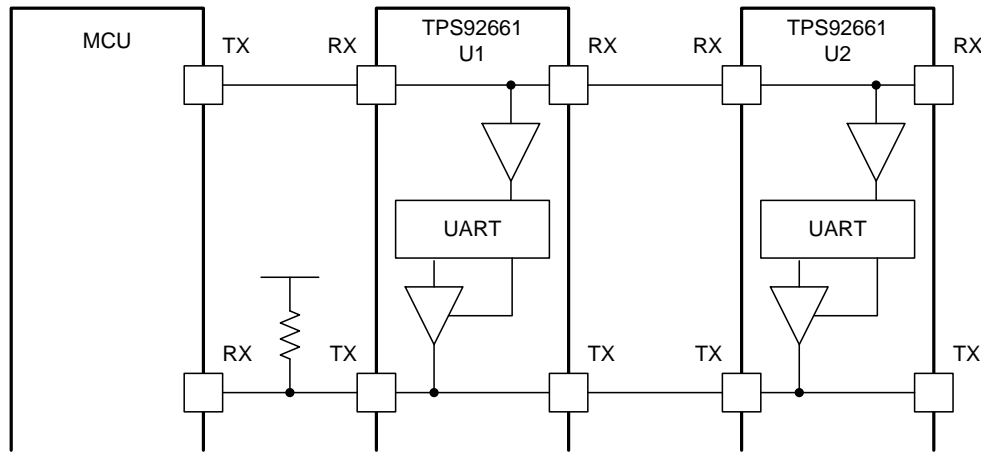

Figure 27. Communications Connections

7.4.4 UART Clock and Baudrate

The UART operates with eight data bits, one stop bit and no parity (8 – 1). Figure 28 shows the waveform for an individual byte transfer on the TTL UART.

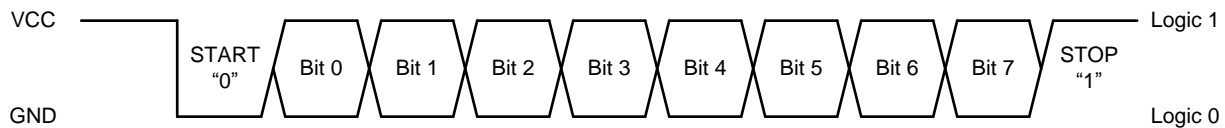

Figure 28. UART 8 – 1 Signaling

A logic “1” state occurs when the device drives the line to the VCC voltage. A logic “0” state occurs when the device drives the line to system ground. The line remains in the high/logic “1” state when idle. Figure 29 and Figure 30 illustrate sending actual data bytes and are intended to represent what an actual UART waveform displays on an oscilloscope or logic analyzer.

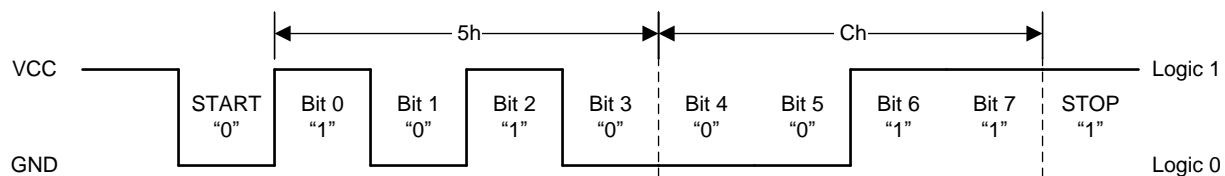

Figure 29. UART Sending 0x26 Byte (0010 0110)

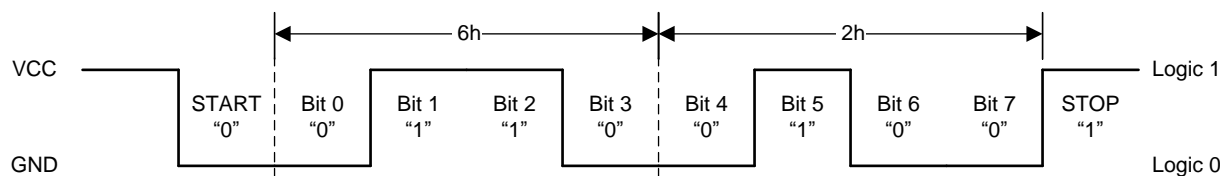

Figure 30. UART Sending 0x26

The baud rate is based on the CLOCK input and is one-sixteenth of the CLOCK input frequency (see Table 1 for some examples). The UART uses 16x oversampling on the incoming asynchronous RX signal.

Table 1. UART Baud Rate Examples

CLK FREQUENCY (MHz)	BAUD RATE (kbps)
6.4	400
8.0	500
12.8	800
16.0	1000

Set the master microcontroller unit to support the same baud rate as is defined by the input CLOCK frequency.

7.4.5 UART Communications Reset

The microcontroller unit can reset the device UART and protocol state machine at any time by holding the RX input low for a period of at least 12 bit times (16×12 CLK periods). This period signifies a break in communications and causes the TPS92661 devices on the network to reset to a known-good state for receiving the next command frame. The device immediately aborts any response frames in progress.

NOTE

A communications reset does not reset the registers and does not halt normal LED PWM operation.

7.4.6 UART Device Addressing

Connecting terminals ADR2, ADR1, and ADR0 to GND or VCC sets the device address for each TPS92661 device. This allows up to eight different devices (addressable (0h to 7h)) for a total of $8 \times 12 = 96$ LEDs per array. See [Table 2](#) for device address configuration.

Table 2. Device Address Configurations

ADR2	ADR1	ADR0	DEVICE ADDRESS
0	0	0	0
0	0	1	1
0	1	0	2
0	1	1	3
1	0	0	4
1	0	1	5
1	1	0	6
1	1	1	7

7.4.7 UART Communications Protocol

The UART communication process uses a command/response protocol mastered by the MCU to write and read the registers on each TPS92661 device. This means that the TPS92661 device never initiates traffic onto the network. The protocol maps the registers into an address space on each device. All of the registers are read-write (R/W). See the [Registers](#) section for a register list.

The MCU uses the protocol to initiate a communication transaction by sending a command frame. This command frame addresses either one TPS92661 device directly or broadcasts to all TPS92661 devices on the network. This addressing may cause a response frame to be sent back from the slave TPS92661 device depending on the command type of the command frame. There are three types of command frames:

- **Single Device Write** from MCU to a specific TPS92661 device (1, 2, 5, 10 or 15 bytes of data)
- **Single Device Read** from MCU to a specific TPS92661 device (1, 2, 5, 10 or 15 bytes of data)
- **Broadcast Write** from the MCU to all TPS92661 devices (0, 1, 2, 5, 10 or 15 bytes of data)

There is only one response frame type. An addressed slave following a 'Single Device Read' command from the master MCU sends his frame type.

All command and response frames are multi-byte and the total number of transmitted bytes depends on the specific command type being communicated.

7.4.7.1 Example 1:

Command frame with CMD_TYPE = “2” (Single Device Write of 5 Bytes):

DESCRIPTION	NUMBER OF BYTES
Command Frame Init	1
Starting Register Address	1
Data	5
CRC	2
Total	9

7.4.7.2 Example 2:

Response frame with RESP_BYTES = ”2”:

DESCRIPTION	NUMBER OF BYTES
Response Frame Init	1
Data	2
CRC	2
Total	5

7.4.7.3 Example 3:

Broadcast Write Synchronization Command frame (Init = B8h):

DESCRIPTION	NUMBER OF BYTES
Command Frame Init	1
CRC	2
Total	3

 The [Transaction Frame Description](#) section describes the construction of these frames and the various byte types transmitted.

7.4.8 Transaction Frame Description

There are four byte-types used within a transaction frame. These include the following:

- Frame Initialization (1 byte)
- Register Address (1 byte)
- N Data Bytes (N = 0, 1, 2, 5, 10 or 15)
- Cyclic Redundancy Code (CRC) error checking (2 bytes)

Write & Read Command Frame Structure:

Cmd Frame Init	Register Address	N Bytes of Data	CRC checksum
----------------	------------------	-----------------	--------------

Response Frame Structure:

Rsp Frame Init	N Bytes of Data	CRC checksum
----------------	-----------------	--------------

Synchronization Command Frame Structure:

Cmd Frame Init	CRC checksum
----------------	--------------

7.4.9 Frame Initialization Byte

The frame initialization byte identifies the frame as being either a command frame or response frame. The command frame byte includes fields specifying the request type (which details the number of bytes to be sent) and the slave device ID. The response frame includes the number of bytes to be received by the microcontroller.

	7	6	5	4	3	2	1	0
Command Frame Init	FRM_TYPE = 1	CMD_TYPE			DEVID_DATAcnt			
Response Frame Init	FRM_TYPE = 0	RESERVED			RESP_BYTES			

The fields shown in the frame initialization byte above are described in the table below.

	Value (Binary)	# of Bytes in Frame	Description
FRM_TYPE Bit 7	0		Response Frame
	1		Command Frame
CMD_TYPE Bits 6:3	0000	5	Single Device Write (1 byte of data)
	0001	6	Single Device Write (2 bytes of data)
	0010	9	Single Device Write (5 bytes of data)
	0011	14	Single Device Write (10 bytes of data)
	0100	19	Single Device Write (15 bytes of data)
	0101		Reserved
	0110		Reserved
	0111	4+n	Broadcast Write (see DEVID_DATAcnt for number of bytes of data)
	1000	4	Single Device Read (1 byte of data)
	1001	4	Single Device Read (2 bytes of data)
	1010	4	Single Device Read (5 bytes of data)
	1011	4	Single Device Read (10 bytes of data)
	1100	4	Single Device Read (15 bytes of data)
	1101		Reserved
	1110		Reserved
1111		Reserved	
DEVID_DATAcnt Bits 2:0	For Single Device Write or Read:		
	bbb		3-bit device ID (defined by the terminals ADR2...ADR0)
	For Broadcast Write:		
	000		Synchronization Command (no data)
	001		1 byte of data
	010		2 bytes of data
	011		5 bytes of data
	100		10 bytes of data
	101		15 bytes of data
110-111		Reserved. These values are reserved for future use and must not be written.	
RESP_BYTES Bits 2:0	000		1 data byte to follow (plus two bytes for CRC)
	001		2 data bytes to follow (plus two bytes for CRC)
	010		5 data bytes to follow (plus two bytes for CRC)
	011		10 data bytes to follow (plus two bytes for CRC)
	100		15 data bytes to follow (plus two bytes for CRC)
	101-111		Reserved

7.4.10 Register Address

The protocol allows 1, 2, 5, 10 or 15 successive register locations from the addressed register to be written by a single command frame. The register address byte identifies the first TPS92661 device register being written or read, as described in the *Register Map* section.

7.4.11 Data Bytes

The frame initialization byte specifies the number of data bytes to be included in the frame.

7.4.12 CRC Bytes

CRC-16-IBM calculates the CRC bytes. The CRC bytes allow detection of errors within the transaction frame. The device increments the CRC Error Count Register (CERRCNT) each time a CRC error occurs (see *Register Map* for details).

7.4.13 Registers

The registers in the TPS92661 device contain programmed information and operating status. During the power-up period, the TPS92661 device resets the registers to the default values as listed below. Register addresses marked RESERVED or not shown in the register map may be written with any value but always returns a 0.

7.4.13.1 LED ON Registers

The device stores the **LED ON** registers (**LEDxON**) for each individual LED with 10-bit resolution and organizes them as groups of five bytes for every four LEDs. This organization creates a total of 15 LED ON registers for the string of 12 LEDs. The address range used for these registers is 00h to 0Eh. Refer to [Table 7](#) for complete list of LED ON registers.

ADDR	REGISTER	D7	D6	D5	D4	D3	D2	D1	D0	DEFAULT
00h	LED1ONL	LED1ON[7:0]								00000000
01h	LED2ONL	LED2ON[7:0]								00000000
02h	LED3ONL	LED3ON[7:0]								00000000
03h	LED4ONL	LED4ON[7:0]								00000000
04h	LED1_4ONH	LED4ON[9:8]	LED3ON[9:8]		LED2ON[9:8]		LED1ON[9:8]		00000000	

LEDxON[9:0] defines the count value within the 10-bit TCNT period when bypass switch x should be **opened** to turn LEDx on (x = 1 to 12).

7.4.13.2 LED OFF Registers

The device stores the **LED OFF** registers (**LEDxOFF**) for each individual LED with 10-bit resolution and organizes them as groups of five bytes for every four LEDs. This organization creates a total of 15 LED OFF registers for the string of 12 LEDs. The address range used for these registers is 20h to 2Eh. Refer to [Table 7](#) for complete list of LED OFF registers.

ADDR	REGISTER	D7	D6	D5	D4	D3	D2	D1	D0	DEFAULT
20h	LED1OFFL	LED1OFF[7:0]								00000000
21h	LED2OFFL	LED2OFF[7:0]								00000000
22h	LED3OFFL	LED3OFF[7:0]								00000000
23h	LED4OFFL	LED4OFF[7:0]								00000000
24h	LED1_4OFFH	LED4OFF[9:8]	LED3OFF[9:8]		LED2OFF[9:8]		LED1OFF[9:8]		00000000	

LEDxOFF[9:0] defines the count value within the 10-bit TCNT period when bypass switch x should be **closed** to turn LEDx off (x = 1 to 12).

7.4.13.3 Alternate LED On/Off Registers

In the low address space starting at 00h that is defined above, all of the LEDxOFF registers follow all of the LEDxON registers. The higher address space starting at 40h maps the LEDxON and LEDxOFF pairs together so that the device requires a write of only 10 data bytes to update both the on and the off times for a given set of four LEDs. The registers that exist at addresses {40h-5Dh} are an alias for the registers that exist at addresses {0h-0Eh, 20h-2Eh}. In other words, a write to the register at address 00h affects the register contents at address 40h, and vice versa.

7.4.13.4 Enable Registers

The **ENABLE** registers (**ENON** and **ENOFF**) determine whether a particular LEDxON or LEDxOFF value is enabled. In other words, an LED turns on only when TCNT reaches LEDxON if the corresponding ENON bit is set. Conversely, an LED turns off only when TCNT reaches LEDxOFF if the corresponding ENOFF bit is set. In this way, LEDs may be turned on fully, turned off fully, or modulated at a given duty cycle by programming the appropriate ENON and ENOFF register bits.

ADDR	REGISTER	D7	D6	D5	D4	D3	D2	D1	D0	DEFAULT
B0h	ENONL	ENON[8:1]								00000000
B1h	ENONH	RESERVED				ENON[12:9]				00000000
B2h	ENOFFL	ENOFF[8:1]								00000000
B3h	ENOFFH	RESERVED				ENOFF[12:9]				00000000

ENON[12:1] determine whether the device uses the corresponding LEDxON to turn on the LED.

- 0 = Do nothing when TCNT = LEDxON
- 1 = Turn LED on when TCNT = LEDxON

ENOFF[12:1] determine whether the device uses the corresponding LEDxOFF to turn off the LED.

- 0 = Do nothing when TCNT = LEDxOFF
- 1 = Turn LED off when TCNT = LEDxOFF

7.4.13.5 Control Registers

The control registers allow control and monitoring of several functions. The control registers occupy addresses C0h through C5h.

7.4.13.5.1 PWM Clock Divider Register (PCKDIV)

ADDR	REGISTER	D7	D6	D5	D4	D3	D2	D1	D0	DEFAULT
C0h	PCKDIV	RSVD	RSVD	DDEC[1:0]		RSVD	DPWR2[2:0]			00000011

DPWR2[2:0]: This 3-bit value sets the power-of-2 divider for the incoming CLK signal before sending it to the decimal divider. Power-of-2 divider mapping:

DPWR2[2:0]	Divide by:
0	2
1	4
2	8
3	16
4	32
5	64
6	reserved ⁽¹⁾
7	reserved ⁽¹⁾

The default value of DPWR2 is 3. This sets the initial power-of-2 divider to divide-by-16 at reset.

DDEC[1:0]: This 2-bit value sets the decimal divider for the internal signal coming from the power-of-2 divider. Decimal divider mapping:

DDEC1:0]	Divide by:
0	1
1	3
2	5
3	reserved ⁽¹⁾

The default value of DDEC is 0. This sets the initial decimal divider to divide-by-1 at reset. Using the two serially connected dividers in combination, clock dividers of various values are possible.

(1) If any of the reserved values are written to DPWR2[2:0] or DDEC[1:0], the PWM clock divider is set to divide-by-16, regardless of any other settings.

PWM Clock Divider

Examples:

DPWR2[2:0] = 0

DDEC[1:0] = 0

→ PWM Clock = CLK / 2

DPWR2[2:0] = 1

DDEC[1:0] = 2

→ PWM Clock = CLK / 20

7.4.13.5.2 System Configuration Register (SYSCFG)

ADDR	REGISTER	D7	D6	D5	D4	D3	D2	D1	D0	DEFAULT
C1h	SYSCFG	RESERVED				CKWEN	CMWEN	SCMAST	PWR	00000000

PWR: This bit is reset to 0 upon power-up or EN low. It may be written to a 1 by the micro-controller (MCU). Reading this bit allows the MCU to detect when there has been a power cycle.

- 0 = A power cycle or EN low has occurred since last write to a '1'
- 1 = No power cycle or EN low has occurred since the last write to a '1'

SCMAST: The Synchronization Master bit determines whether the TPS92661 device is a synchronization master or not. There should be only ONE Sync Master in the system.

- 0 = Slave. A high input value on SYNC resets TCNT to 0.
- 1 = Master. The TPS92661 device generates a high pulse one CLK cycle long on SYNC when TCNT = 1023 and the PWM clock divider is about to roll over. SYNC may be connected to the next TPS92661 device in order to synchronize multiple TPS92661 devices with respect to each other.

CMWEN: Communications Watchdog Timer Enable.

- 0 = Communications watchdog timer disabled
- 1 = Communications watchdog timer enabled

CKWEN: Clock Watchdog Timer Enable

- 0 = Clock watchdog timer disabled
- 1 = Clock watchdog timer enabled

7.4.13.6 Default LED State Register (DEFLED)

ADDR	REGISTER	D7	D6	D5	D4	D3	D2	D1	D0	DEFAULT
C2h	DEFLEDL	DEFLED[8:1]								00000000
C3h	DEFLEDH	RESERVED				DEFLED[12:9]				00000000

DEFLED[12:1]: Default LED State register. This register determines which state to place the LED in when one of the watchdog timers times out.

- 0 = LED off
- 1 = LED on

7.4.13.7 PWM Period Counter Register (TCNT)

ADDR	REGISTER	D7	D6	D5	D4	D3	D2	D1	D0	DEFAULT
C4h	TCNTL	TCNT[7:0]								00000000
C5h	TCNTH	RESERVED						TCNT[9:8]		00000000

TCNT[9:0]: This is the PWM period count value. The TCNT register automatically counts from 0 to 1023 and wraps. It is provided here with read/write access for diagnostic purposes. Writes to the TCNT register are loaded upon the next rising edge of CLK when there is a SYNC pulse present.

7.4.13.8 Diagnostic Registers

The diagnostic registers hold the results of various faults and status flags for the system. The diagnostic registers exist in the address range E0h to E2h.

ADDR	REGISTER	D7	D6	D5	D4	D3	D2	D1	D0	DEFAULT
E0h	FAULTL	FAULT[8:1]								00000000
E1h	FAULTH	RESERVED				FAULT[12:9]				00000000
E2h	CERRCNT	CERRCNT[7:0]								00000000

FAULT[12:1]: Fault Register

- 0 = an LED fault has not occurred
- 1 = an LED fault has occurred

The LED open and short fault detection circuitry is sampled just before the corresponding bypass switch is closed. If a fault exists at this time instant, a 1 is latched into the associated FAULT register bit. The FAULT register bits must be cleared manually by writing them back to 0. If an LED fault condition still exists at the next PWM period, the device immediately resets the corresponding FAULT register bit to a 1. Writing the FAULT register bits to 1 has no effect.

CERRCNT[7:0]: CRC Error Count Register

This register value is incremented each time a CRC error is received. This register may be read by the MCU and then written back to 0 to clear the count. The CERRCNT value saturates at FFh; it does not wrap back to 0 when it reaches FFh. The CERRCNT register is not automatically cleared when a communications reset is received. It must be cleared manually by writing it back to 0. Note that the CERRCNT register can be written to any 8-bit value. This is intended for diagnostic purposes.

7.5 Programming

7.5.1 Read / Write Register Flow Chart

7.5.1.1 Register Write Flow Chart

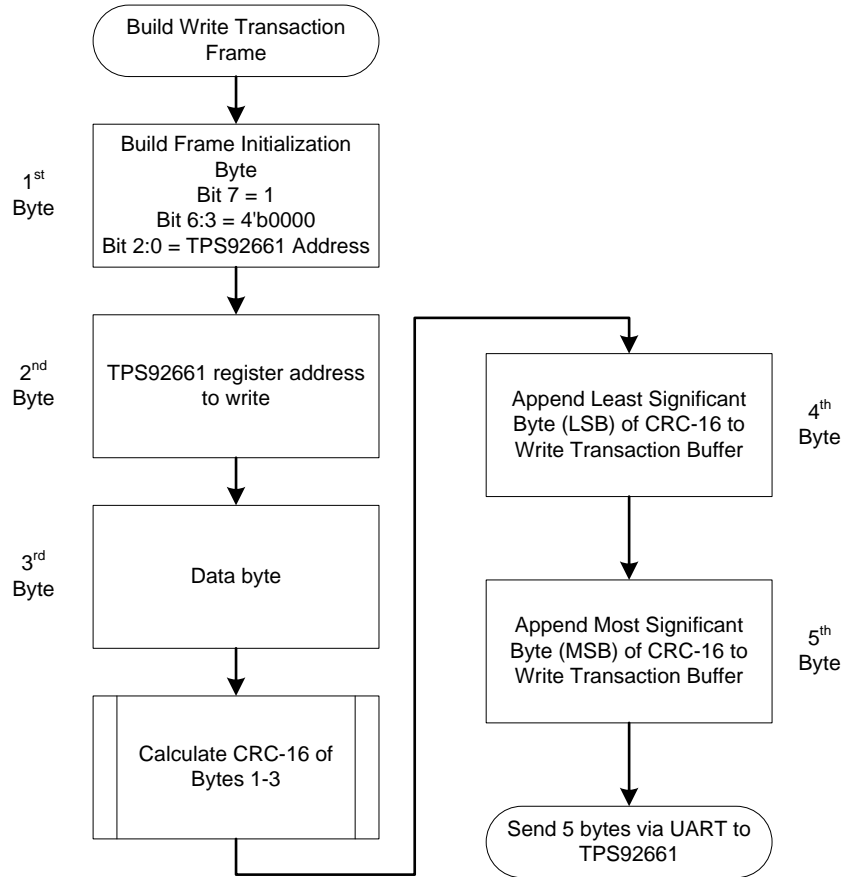

Figure 31. Register Write Example

Programming (continued)

7.5.1.2 Register Read Flow Chart

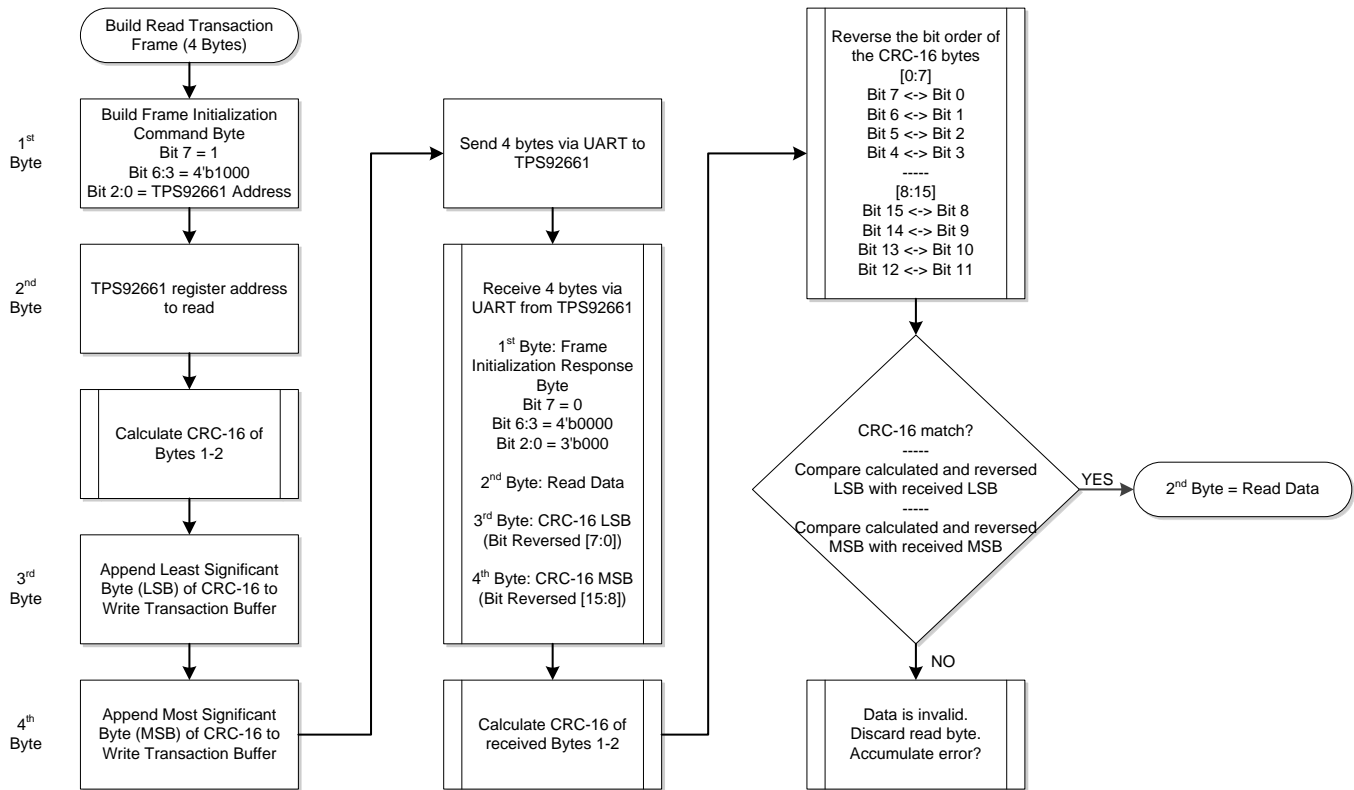

Figure 32. Register Read Example

7.5.2 Complete Transaction Example

The pseudo-code below shows a pair of transactions: a write of the LEDOFF times for LEDs 1-4 followed by a read of the same registers (LED1OFF = 200, LED2OFF = 410, LED3OFF = 620, LED4OFF = 830).

Table 3. Write Command (MCU-to-TPS92661 Device)

tx_init (0x90)	Single device write of 5 bytes (Device ID = 0)
tx_addr (0x20)	Register address = 0x20 (LED1OFFL)
tx_data (0xc8)	LED1OFFL = Low_Byte (200)
tx_data (0x9a)	LED2OFFL = Low_Byte (410)
tx_data (0x6c)	LED3OFFL = Low_Byte (620)
tx_data (0x3e)	LED4OFFL = Low_Byte (830)
tx_data (0xe4)	LED1_4OFFH = High_Byte (830) << 6
	High_Byte (620) << 4
	High_Byte (410) << 2
	High_Byte (200)
tx_crc1 (0x88)	CRC1 = Low_Byte (CRC-16-IBM)
tx_crc2 (0x57)	CRC2 = High_Byte (CRC-16-IBM)

Table 4. Read Command (MCU-to-TPS92661 Device)

tx_init (0xd0)	Single device read of 5 bytes (Device ID = 0)
tx_addr (0x20)	Register address = 0x20 (LED1OFFL)
tx_crc1 (0x5c)	CRC1 = Low_Byte (CRC-16-IBM)
tx_crc2 (0x18)	CRC2 = High_Byte (CRC-16-IBM)

Table 5. Read Response (MCU-to-TPS92661 Device)

rx_init (0x02)	Read Response, 5 data bytes to follow	
rx_data (0xc8)	LED1OFFL = Low_Byte (200)	
rx_data (0x9a)	LED2OFFL = Low_Byte (410)	
rx_data (0x6c)	LED3OFFL = Low_Byte (620)	
rx_data (0x3e)	LED4OFFL = Low_Byte (830)	
rx_data (0xe4)	LED1_4OFFH = High_Byte (830) << 6	
	High_Byte (620) << 4	
	High_Byte (410) << 2	
	High_Byte (200)	
rx_crc1 (0x78)	CRC1 = Low_Byte (CRC-16-IBM)	Must be reversed when read. See CRC Calculation Programming Examples section.
rx_crc2 (0x3b)	CRC2 = High_Byte (CRC-16-IBM)	

As an additional example, the following pseudo-code shows a 2-byte write to TPS92661 Address 5, Register 0xB0 (ENON) with data of 0x55 to register 0xB0 and 0x05 to register 0xB1. Data sent (hex): 8D B0 55 05 D5 D8

Table 6. Write Command (MCU-to-TPS92661 Device)

tx_init (0x8D)	Single device write of 2 bytes (Device ID = 5)
tx_addr (0xB0)	Register address = 0xB0 (ENON)
tx_data (0x55)	ENONL = 0101 0101b
tx_data (0x05)	ENONH = 0000 0101b
tx_crc1 (0xD5)	CRC1 = Low Byte(CRC-16-IBM)
tx_crc2 (0xD8)	CRC2 = High Byte(CRC-16-IBM)

The UART waveform associated with the example in [Table 6](#) is shown in [Figure 33](#).

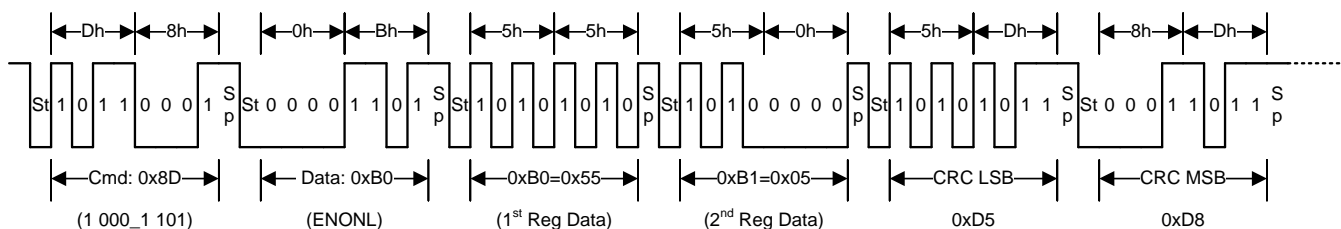
Figure 33. 2-Byte Write Example Waveform

After this write had completed, the device enables all of the odd numbered LEDs (LED1, LED3, ..., LED11) to turn on when TCNT = LEDxON register, while all of the even numbered LEDs remain off.

7.5.3 CRC Calculation Programming Examples

The C function below shows an example of how to generate the CRC bytes correctly for a transmission to the TPS92661 devices:

```

  Uint16 crc_16_ibm(Uint8 *buf, Uint8 len)
  {
    Uint16 crc = 0;
    Uint16 I;

    while (len--){
      crc ^= *buf++;
      for (I = 0; I < 8; I++){
        crc = (crc >> 1) ^ ((crc & 1) ? 0xa001 : 0);
      }
    }
    return crc;
  }

```

The CRC is transmitted LSByte first to/from the TPS92661 device.

Upon reading data from the TPS92661 device, the MCU should calculate and compare the CRC to determine whether valid data was received.

NOTE

The calculated CRC bytes must be bit-reversed before comparison to the received CRC bytes

```

bool is_crc_valid(Uint8 *rx_buf, Uint8 crc_start)
{
  Uint16 crc_calc;          // Calculated CRC
  Uint8  crc_msb, crc_lsb;  // Individual bytes of calculated CRC
  // Calculate the CRC based on bytes received
  crc_calc = crc_16_ibm(rx_buf, crc_start);
  crc_lsb = (crc_calc & 0x00FF);
  crc_msb = ((crc_calc >> 8) & 0x00FF);
  // Perform the bit reversal within each byte
  crc_msb = reverse_byte(crc_msb);
  crc_lsb = reverse_byte(crc_lsb);
  // Do they match?
  if((*rx_buf + crc_start) == crc_lsb) && (*(rx_buf + crc_start + 1) == crc_msb){
    return TRUE;
  }
  else{
    return FALSE;
  }
}

```

One way to perform the bit reversal is shown in the following C code:

```

  Uint8 reverse_byte(Uint8 byte)
  {
    // First, swap the nibbles
    byte = (((byte & 0xF0) >> 4) | ((byte & 0x0F) << 4));
    // Then, swap bit pairs
    byte = ((byte & 0xCC) >> 2) | ((byte & 0x33) << 2);
    // Finally, swap adjacent bits
    byte = ((byte & 0xAA) >> 1) | ((byte & 0x55) << 1);
    // We should now be reversed (bit 0 <--> bit 7, bit 1 <--> bit 6, etc.)
    return byte;
  }

```

7.5.4 Code Examples to Implement Register Reads/Writes

The C functions below show examples of how to code a single register write and single register read. It is recommended that the user get this code running first and then expand to some of the other commands and multi-byte reads and writes.

Write Example:

```

void lmm_wr_1_reg(Uint8 lmm, Uint8 regaddr, Uint8 data)
{
  Uint8 TxBuf[5];

```

```

    Uint16 I;

    // We must first assemble the bytes and CRC them
    TxBuf[0] = (0x80 | lmm);
    TxBuf[1] = regaddr;
    TxBuf[2] = data;
    // Get the CRC back
    I = crc_16_ibm(TxBuf, 3);
    // Process and store bytes
    TxBuf[3] = (I & 0x00FF); // LSByte
    TxBuf[4] = ((I >> 8 & 0x00FF); // MSByte

    /* INSERT MCU-SPECIFIC UART CODE HERE */
    // Now we can send it to the matrix network
    for(I = 0; I < 5; I++){
        lmm_uart_xmit(TxBuf[i]);
    }
}

```

Read Example:

```

    Uint8 lmm_rd_1_reg(Uint8 lmm, Uint8 regaddr)
    {
        /* DATA WILL BE AVAILABLE IN RxBuf ON RETURN */
        Uint8 TxBuf[4];
        Uint16 I;

        // We must first assemble the request and CRC it
        TxBuf[0] = (0xC0 | lmm);
        TxBuf[1] = regaddr;
        // Get the CRC back
        I = crc_16_ibm(TxBuf, 2);
        // Process and store bytes
        TxBuf[2] = (I & 0x00FF); // LSByte
        TxBuf[3] = ((I >> 8) & 0x00FF); // MSByte

        // Also make sure we are prepared to receive the data from the LMM
        ReturnBytes = 1+1+2; // This is the number of bytes we expect to get back
        /* 1 Response Frame Init + 1 Data + 2 CRC */
        GatheredBytes = 0;

        /* INSERT MCU-SPECIFIC UART CODE HERE */
        // Now we can send it to the matrix network
        for(I = 0; I < 4; I++){
            lmm_uart_xmit(TxBuf[i]);
        }

        /* INSERT MCU-SPECIFIC UART CODE HERE */
        // Now we can send the request to the matrix network
        // This is basically pseudo-code for however your MCU receive works
        while(GatheredBytes != 4);

        // Check the CRC (should be in RxBuf[2] and [3])
        if(is_crc_valid(RxBuf, 2)){
            return TRUE;
        }
        else{
            return FALSE;
        }
    }
}

```

7.6 Register Map

Table 7. Register Map

ADDR	REGISTER	D7	D6	D5	D4	D3	D2	D1	D0	DEFAULT
LED ON REGISTERS										
00h	LED1ONL	LED1ON[7:0]							00000000	
01h	LED2ONL	LED2ON[7:0]							00000000	
02h	LED3ONL	LED3ON[7:0]							00000000	
03h	LED4ONL	LED4ON[7:0]							00000000	

Register Map (continued)
Table 7. Register Map (continued)

ADDR	REGISTER	D7	D6	D5	D4	D3	D2	D1	D0	DEFAULT	
04h	LED1_4ONH	LED4ON[9:8]		LED3ON[9:8]		LED2ON[9:8]		LED1ON[9:8]		00000000	
05h	LED5ONL	LED5ON[7:0]									00000000
06h	LED6ONL	LED6ON[7:0]									00000000
07h	LED7ONL	LED7ON[7:0]									00000000
08h	LED8ONL	LED8ON[7:0]									00000000
09h	LED5_8ONH	LED8ON[9:8]		LED7ON[9:8]		LED6ON[9:8]		LED5ON[9:8]		00000000	
0Ah	LED9ONL	LED9ON[7:0]									00000000
0Bh	LED10ONL	LED10ON[7:0]									00000000
0Ch	LED11ONL	LED11ON[7:0]									00000000
0Dh	LED12ONL	LED12ON[7:0]									00000000
0Eh	LED9_12ONH	LED12ON[9:8]		LED11ON[9:8]		LED10ON[9:8]		LED9ON[9:8]		00000000	
LED OFF REGISTERS											
20h	LED1OFFL	LED1OFF[7:0]									00000000
21h	LED2OFFL	LED2OFF[7:0]									00000000
22h	LED3OFFL	LED3OFF[7:0]									00000000
23h	LED4OFFL	LED4OFF[7:0]									00000000
24h	LED1_4OFFH	LED4OFF[9:8]		LED3OFF[9:8]		LED2OFF[9:8]		LED1OFF[9:8]		00000000	
25h	LED5OFFL	LED5OFF[7:0]									00000000
26h	LED6OFFL	LED6OFF[7:0]									00000000
27h	LED7OFFL	LED7OFF[7:0]									00000000
28h	LED8OFFL	LED8OFF[7:0]									00000000
29h	LED5_8OFFH	LED8OFF[9:8]		LED7OFF[9:8]		LED6OFF[9:8]		LED5OFF[9:8]		00000000	
2Ah	LED9OFFL	LED9OFF[7:0]									00000000
2Bh	LED10OFFL	LED10OFF[7:0]									00000000
2Ch	LED11OFFL	LED11OFF[7:0]									00000000
2Dh	LED12OFFL	LED12OFF[7:0]									00000000
2Eh	LED9_12OFFH	LED12OFF[9:8]		LED11OFF[9:8]		LED10OFF[9:8]		LED9OFF[9:8]		00000000	
LED ONOFF REGISTERS (Remapped LED ON and LED OFF Registers)											
40h	LED1ONL	LED1ON[7:0]									00000000
41h	LED2ONL	LED2ON[7:0]									00000000
42h	LED3ONL	LED3ON[7:0]									00000000
43h	LED4ONL	LED4ON[7:0]									00000000
44h	LED1_4ONH	LED4ON[9:8]		LED3ON[9:8]		LED2ON[9:8]		LED1ON[9:8]		00000000	
45h	LED1OFFL	LED1OFF[7:0]									00000000
46h	LED2OFFL	LED2OFF[7:0]									00000000
47h	LED3OFFL	LED3OFF[7:0]									00000000
48h	LED4OFFL	LED4OFF[7:0]									00000000
49h	LED1_4OFFH	LED4OFF[9:8]		LED3OFF[9:8]		LED2OFF[9:8]		LED1OFF[9:8]		00000000	
4Ah	LED5ONL	LED5ON[7:0]									00000000
4Bh	LED6ONL	LED6ON[7:0]									00000000
4Ch	LED7ONL	LED7ON[7:0]									00000000
4Dh	LED8ONL	LED8ON[7:0]									00000000
4Eh	LED5_8ONH	LED8ON[9:8]		LED7ON[9:8]		LED6ON[9:8]		LED5ON[9:8]		00000000	
4Fh	LED5OFFL	LED5OFF[7:0]									00000000
50h	LED6OFFL	LED6OFF[7:0]									00000000
51h	LED7OFFL	LED7OFF[7:0]									00000000

Register Map (continued)
Table 7. Register Map (continued)

ADDR	REGISTER	D7	D6	D5	D4	D3	D2	D1	D0	DEFAULT
52h	LED8OFFL	LED8OFF[7:0]								00000000
53h	LED5_8OFFH	LED8OFF[9:8]		LED7OFF[9:8]		LED6OFF[9:8]		LED5OFF[9:8]		00000000
54h	LED9ONL	LED9ON[7:0]								00000000
55h	LED10ONL	LED10ON[7:0]								00000000
56h	LED11ONL	LED11ON[7:0]								00000000
57h	LED12ONL	LED12ON[7:0]								00000000
58h	LED9_12ONH	LED12ON[9:8]		LED11ON[9:8]		LED10ON[9:8]		LED9ON[9:8]		00000000
59h	LED9OFFL	LED9OFF[7:0]								00000000
5Ah	LED10OFFL	LED10OFF[7:0]								00000000
5Bh	LED11OFFL	LED11OFF[7:0]								00000000
5Ch	LED12OFFL	LED12OFF[7:0]								00000000
5Dh	LED9_12OFFH	LED12OFF[9:8]		LED11OFF[9:8]		LED10OFF[9:8]		LED9OFF[9:8]		00000000
ENABLE REGISTERS										
B0h	ENONL	ENON[8:1]								00000000
B1h	ENONH	RESERVED				ENON[12:9]				00000000
B2h	ENOFFL	ENOFF[8:1]								00000000
B3h	ENOFFH	RESERVED				ENOFF[12:9]				00000000
CONTROL REGISTERS										
C0h	PCKDIV	RSVD	RSVD	DDEC[1:0]		RSVD	DPWR2[2:0]			00000011
C1h	SYSCFG	RESERVED				CKWEN	CMWEN	SCMAST	PWR	00000000
C2h	DEFLEDL	DEFLED[8:1]								00000000
C3h	DEFLEDH	RESERVED				DEFLED[12:9]				00000000
C4h	TCNTL	TCNT[7:0]								00000000
C5h	TCNTH	RESERVED						TCNT[9:8]		00000000
DIAGNOSTIC REGISTERS										
E0h	FAULTL	FAULT[8:1]								00000000
E1h	FAULTH	RESERVED				FAULT[12:9]				00000000
E2h	CERRCNT	CERRCNT[7:0]								00000000

8 Application and Implementation

8.1 Applications Information

The TPS92661 is capable of shunting any combination of 12 series LEDs at high frequency and at variable duty cycles. This type of application requires a high bandwidth current source. The TPS92661 was developed using a high-side sensing hysteretic buck current source and it is this type that is recommended to power the LED channels. boost and/or buck-boost inputs may also be used, but makes the implementation more complicated and lower performance.

8.1.1 Guidelines For Current Source

- Operate at a switching frequency at least 250 times the TPS92661 PWM frequency. A switching frequency between 500 times the PWM frequency and 2000 times the PWM frequency is recommended.
- Operate current source in CCM (continuous conduction mode).
- Minimize capacitance on each LED channel (capacitance between LED0 and LED12) to avoid excessive over and undershoot when dimming.
- Monitor the current source output current during dimming to ensure the source is staying close to its DC set-point level.
- Follow the [Layout Guidelines](#).

8.2 Design Examples

This section offers two design examples. Each helps illustrate how the thermal limitations of a design can vary depending on overall operating conditions and how the overall system temperature limitations directly affect the device current rating for a given design. These temperature limitations must be considered on a case-by-case basis.

8.2.1 12 LED, 1.2-A Application

Step 1. LED Board Requirements

Examine the requirements of the LED load board, assuming the worst case condition: LEDs on continuously. This example assumes a worst case metal core PCB temperature of 125°C to adequately protect the LEDs. Calculate the power required to be dissipated by the LED load board alone using [Equation 4](#).

$$P_{LED_LOAD} = I_{LED} \times V_{LED} \times n = 1.1 \text{ A} \times 3.33 \text{ V} \times 12 = 43.956 \text{ W} \approx 44 \text{ W}$$

where

- n is the number of LEDs (4)

Step 2. Estimate Device Power Dissipation

Use [Figure 1](#) to estimate the power dissipation in the TPS92661 device. Assuming a 6-MHz clock and a 146-Hz PWM frequency at 125°C, 4.2 mA at a 5.5-V VCC. The power dissipation calculation is shown in [Equation 5](#).

$$P_{TPS92661_CONTROL} = 4.2 \text{ mA} \times 5.5 \text{ V} \approx 23 \text{ mW} \quad (5)$$

This value is very small compared to the net power required to be dissipated by the LED load and can be neglected.

Step 3. Estimate Switch Power Dissipation

Calculate the worst case power dissipated in the TPS92661 switches. Using the worst case $R_{ALL(on)}$ of 3400 mΩ for [Equation 6](#).

$$P_{TPS92661_SWITCHES} = (1.12 \text{ A})^2 \times 3400 \text{ m}\Omega = 4.114 \text{ W} \quad (6)$$

Design Examples (continued)

Step 4. Calculate the Temperature Rise

The LED load board controls temperature to a maximum of 125°C. Solder the TPS92661 device to the LED board to create a very good thermal connection. Using the TPS92661 θ_{JB} measurement of 6.1 °C/W, can calculate the temperature rise between the TPS92661 thermal pad and the junction temperature using Equation 7.

$$T_J = T_{BOARD(max)} + T_{RISE} = 125^\circ\text{C} + (4.114 \times 6.1) \approx 150^\circ\text{C}. \quad (7)$$

This is the maximum allowable junction temperature. Any time a TPS92661 internal switch is active, the net power dissipated by the LED load board is reduced.

A properly designed LED load board inherently supports the additional power dissipation of the TPS92661 device. In this example, if all of the TPS92661 internal switches are on, the LED load board thermal loading reduces from 44 W to 4.114 W.

8.2.2 6 LED, 1.5-A Application

The TPS92661 can be used for LED loads from 1 to 12 LEDs. When configuring for connections having fewer than 12 LEDs, the LEDs should be connected as shown in Figure 34.

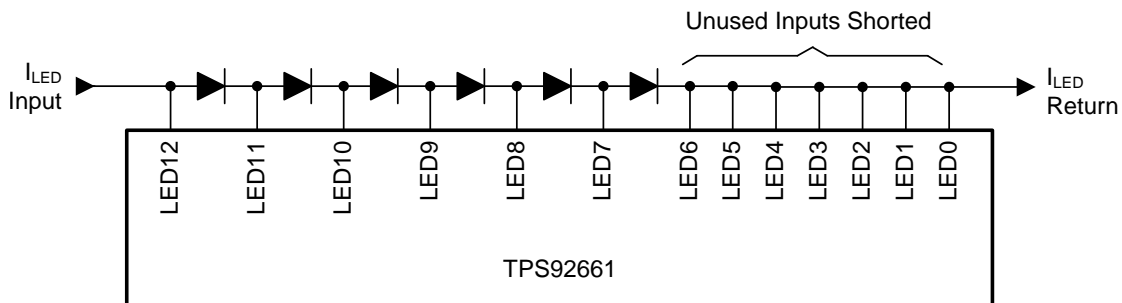

Figure 34. TPS92661 Connection with 6 LEDs

Step 1. Calculate the LED Load Power

As described in the [12 LED, 1.2-A Application](#) section example, the LED load itself drives the heat sink design. Assume the LED load board does not reach a temperature beyond what has been considered for the LEDs. In this case assume the design ensures a maximum heat sink temperature of 90°C for the LED load power calculated in Equation 8.

$$P_{LED_LOAD} = I_{LED} \times V_{LED} \times n = 1.5 \text{ A} \times 3.33 \text{ V} \times 6 \approx 30 \text{ W (max)}$$

where

- n is the number of LEDs (8)

Step 2. Estimate the Power Dissipation

Using Figure 3 estimate the power dissipation of the TPS92661 device. Assuming a 8.57-MHz clock and a 523-Hz PWM frequency at 125°C read 3 mA at a 5.5-V VCC. This amount of power is so low that it can be disregarded.

Step 3. Calculate the Worst Case Switches Power Dissipation

Calculate the maximum all switches on-resistance ($R_{ALL(on)(MAX)}$) value for each of the 6 switches that are in use. Assume the other 6 switches are shorted externally.

$$P_{TPS92661_SWITCHES} = (1.5 \text{ A})^2 \times R_{ALL(on)(MAX)} \times (n/12) = (1.5 \text{ A})^2 \times 3400 \text{ m}\Omega \times (6/12) = 3.825 \text{ W}$$

where

- n is the number of LEDs (9)

Design Examples (continued)

Step 4. Calculate the Temperature Rise

The LED load board controls temperature to a maximum of 90°C. Solder the TPS92661 device to the LED board to create a very good thermal connection. Using the TPS92661 θ_{JB} measurement of 6.1 °C/W, can calculate the temperature rise between the TPS92661 thermal pad and the junction temperature using

$$T_J = T_{BOARD(max)} + T_{RISE} = 90^\circ\text{C} + (3.825 \times 6.1) \approx 113^\circ\text{C} \quad (10)$$

This temperature is well within the TPS92661 operating junction temperature range to provide exceptional performance.

9 Power Supply Recommendations

9.1 General Recommendations

The TPS92661 requires a 5-V supply to power the charge pump, internal logic and references. This rail generates a 3.3-V supply which can be used for the digital communications as outlined in the Internal Regulator section. The TPS92661 device is not compatible with logic levels lower than 3.3 V or greater than 5 V. A separate, high-power supply drives the LED string, as discussed in the [LED Fault Detection and Protection](#) section.

9.2 Internal Regulator

The VCC pin is the output node of the on-board 3.3-V LDO. The VCC pin also acts as the positive voltage rail for the device digital I/Os. If the TPS92661 device is used with a microcontroller with 3.3-V I/Os, then place an output capacitor with a value of at least 0.1 μF at the pin for the internal LDO. Due to the internal linear regulator, an external 3.3-V supply is not required.

If the TPS92661 device is used with 5-V microcontrollers, then the VCC pin **MUST** be tied to the 5-V VIN pin. This connection overrides the internal LDO and allows the digital I/Os to signal at 5 V rather than 3.3 V.

In the rare case that the digital signaling exists at a voltage greater than 3.6 V, but less than 4.5 V, then the VCC pin should be connected to the same voltage as the MCU I/O voltage.

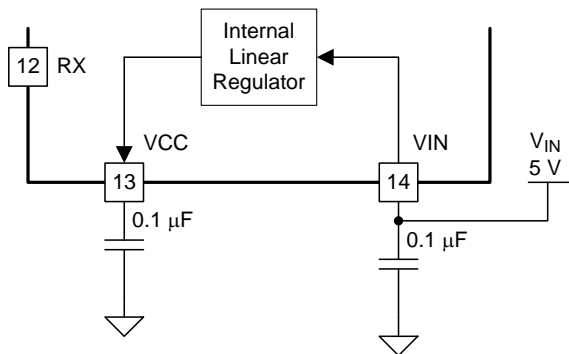

Figure 35. Power Connections for 3.3-V MCU Systems

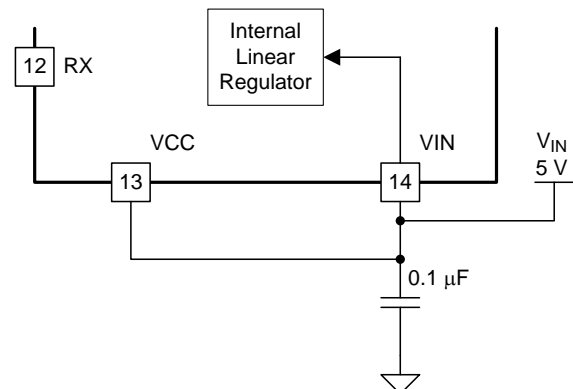

Figure 36. Power Connections for 5-V MCU Systems

Internal Regulator (continued)

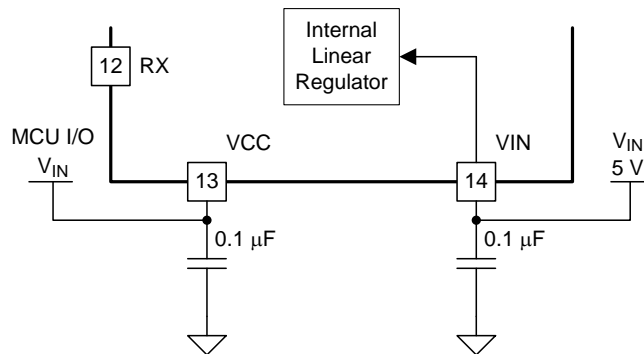

Figure 37. Power Connections for 3.6-V to 4.5-V MCU Systems

9.3 Power Up and Reset

When V_{IN} is greater than V_{IN-UVT} , all bypass switches are initially on (LEDs off) and the LEDs remain off until the device is programmed with the corresponding LED and ENABLE registers. After the registers are programmed, the TPS92661 device modulates the LEDs using the divided-down CLK input as the PWM clock. V_{IN} must be greater than V_{IN-UVT} prior to sourcing current through the LED string in order to ensure a controlled start-up.

The EN input acts as an active-low reset signal for the TPS92661 device. If $EN = 0$, the TPS92661 device resets to the same state as if a power cycle had occurred. All registers are reset to default values and all of the bypass switches are turned on (LEDs off). Once the device emerges from the reset state by setting EN high, the registers must be programmed in order for the device to begin normal operation.

9.4 VIN Power Consumption

Power consumption increases with increased clock frequency, with VIN voltage and with temperature. It is always best to select the lowest VIN and clock frequency the system can tolerate. Guidelines for power drawn by the device from VIN are provided in the [Typical Characteristics](#) section.

9.5 Initialization Set-Up

[Figure 38](#) outlines the steps required to begin communication with a TPS92661 and enable the LEDs. Register Read and Write code examples are shown in the [Programming](#) section.

Initialization Set-Up (continued)

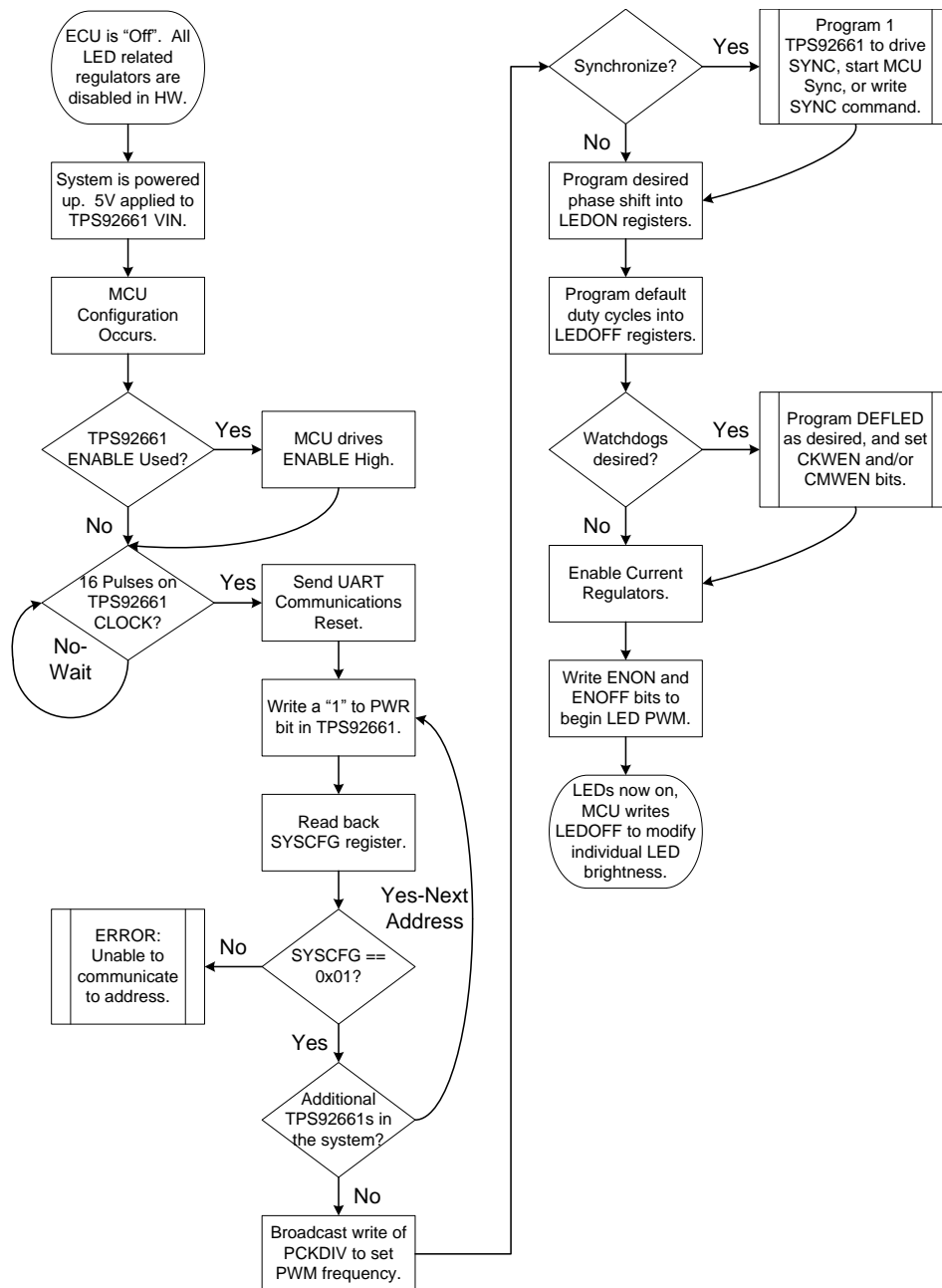

Figure 38. Power Up Sequence

10 Layout

10.1 Layout Guidelines

The final configuration of the LED matrix varies between applications and balances heat dissipation with light output performance. Layout considerations for passive components are simple; place the VCC and VIN decoupling capacitors close to the device and short the traces to the CPP pin capacitor. The bigger challenge is to develop a careful layout plan that efficiently routes the current source for the LED strings.

The communication connections have been designed for ease of routing on a single-sided, metal core board. Each connection has a parallel connection on the opposite side of the device, allowing multiple devices to use a *daisy chain* configuration, easing routing requirements.

10.2 Layout Example

Figure 39 shows a TPS92661 layout example.

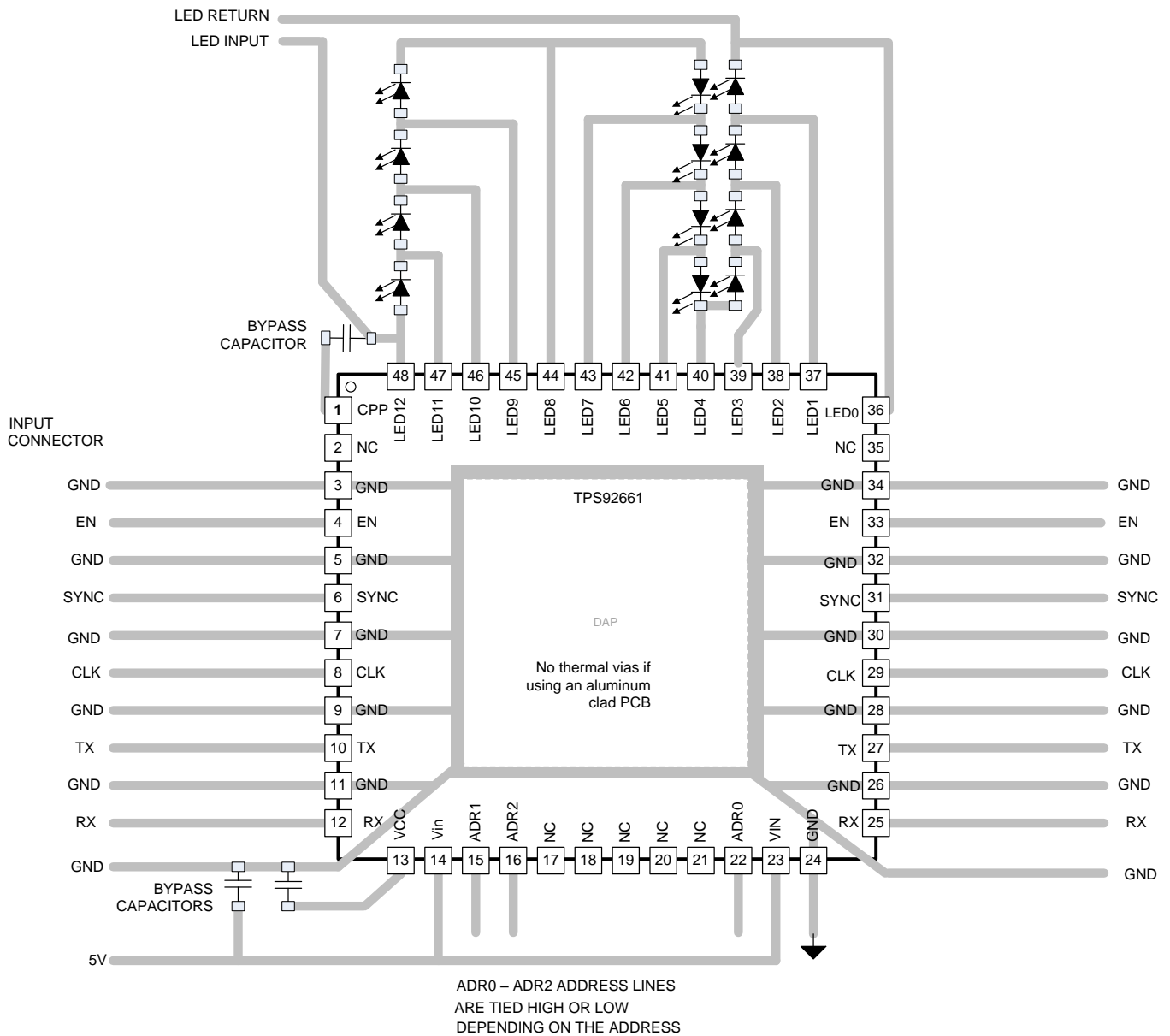

Figure 39. TPS92661 Board Layout

11 Device and Documentation Support

11.1 Trademarks

11.2 Electrostatic Discharge Caution



These devices have limited built-in ESD protection. The leads should be shorted together or the device placed in conductive foam during storage or handling to prevent electrostatic damage to the MOS gates.

11.3 Export Control Notice

Recipient agrees to not knowingly export or re-export, directly or indirectly, any product or technical data (as defined by the U.S., EU, and other Export Administration Regulations) including software, or any controlled product restricted by other applicable national regulations, received from disclosing party under nondisclosure obligations (if any), or any direct product of such technology, to any destination to which such export or re-export is restricted or prohibited by U.S. or other applicable laws, without obtaining prior authorization from U.S. Department of Commerce and other competent Government authorities to the extent required by those laws.

11.4 Glossary

[SLYZ022](#) — *TI Glossary*.

This glossary lists and explains terms, acronyms, and definitions.

12 Mechanical, Packaging, and Orderable Information

The following pages include mechanical packaging and orderable information. This information is the most current data available for the designated devices. This data is subject to change without notice and revision of this document. For browser-based versions of this data sheet, refer to the left-hand navigation.

PACKAGING INFORMATION

Orderable Device	Status (1)	Package Type	Package Drawing	Pins	Package Qty	Eco Plan (2)	Lead/Ball Finish (6)	MSL Peak Temp (3)	Op Temp (°C)	Device Marking (4/5)	Samples
TPS92661QPHPRQ1	ACTIVE	HTQFP	PHP	48	1000	Green (RoHS & no Sb/Br)	CU NIPDAU	Level-2-260C-1 YEAR	-40 to 125	TPS92661Q	Samples

(1) The marketing status values are defined as follows:

ACTIVE: Product device recommended for new designs.

LIFEBUY: TI has announced that the device will be discontinued, and a lifetime-buy period is in effect.

NRND: Not recommended for new designs. Device is in production to support existing customers, but TI does not recommend using this part in a new design.

PREVIEW: Device has been announced but is not in production. Samples may or may not be available.

OBSELETE: TI has discontinued the production of the device.

(2) Eco Plan - The planned eco-friendly classification: Pb-Free (RoHS), Pb-Free (RoHS Exempt), or Green (RoHS & no Sb/Br) - please check <http://www.ti.com/productcontent> for the latest availability information and additional product content details.

TBD: The Pb-Free/Green conversion plan has not been defined.

Pb-Free (RoHS): TI's terms "Lead-Free" or "Pb-Free" mean semiconductor products that are compatible with the current RoHS requirements for all 6 substances, including the requirement that lead not exceed 0.1% by weight in homogeneous materials. Where designed to be soldered at high temperatures, TI Pb-Free products are suitable for use in specified lead-free processes.

Pb-Free (RoHS Exempt): This component has a RoHS exemption for either 1) lead-based flip-chip solder bumps used between the die and package, or 2) lead-based die adhesive used between the die and leadframe. The component is otherwise considered Pb-Free (RoHS compatible) as defined above.

Green (RoHS & no Sb/Br): TI defines "Green" to mean Pb-Free (RoHS compatible), and free of Bromine (Br) and Antimony (Sb) based flame retardants (Br or Sb do not exceed 0.1% by weight in homogeneous material)

(3) MSL, Peak Temp. - The Moisture Sensitivity Level rating according to the JEDEC industry standard classifications, and peak solder temperature.

(4) There may be additional marking, which relates to the logo, the lot trace code information, or the environmental category on the device.

(5) Multiple Device Markings will be inside parentheses. Only one Device Marking contained in parentheses and separated by a "-" will appear on a device. If a line is indented then it is a continuation of the previous line and the two combined represent the entire Device Marking for that device.

(6) Lead/Ball Finish - Orderable Devices may have multiple material finish options. Finish options are separated by a vertical ruled line. Lead/Ball Finish values may wrap to two lines if the finish value exceeds the maximum column width.

Important Information and Disclaimer:The information provided on this page represents TI's knowledge and belief as of the date that it is provided. TI bases its knowledge and belief on information provided by third parties, and makes no representation or warranty as to the accuracy of such information. Efforts are underway to better integrate information from third parties. TI has taken and continues to take reasonable steps to provide representative and accurate information but may not have conducted destructive testing or chemical analysis on incoming materials and chemicals. TI and TI suppliers consider certain information to be proprietary, and thus CAS numbers and other limited information may not be available for release.

In no event shall TI's liability arising out of such information exceed the total purchase price of the TI part(s) at issue in this document sold by TI to Customer on an annual basis.

TAPE AND REEL INFORMATION



QUADRANT ASSIGNMENTS FOR PIN 1 ORIENTATION IN TAPE



*All dimensions are nominal

Device	Package Type	Package Drawing	Pins	SPQ	Reel Diameter (mm)	Reel Width W1 (mm)	A0 (mm)	B0 (mm)	K0 (mm)	P1 (mm)	W (mm)	Pin1 Quadrant
TPS92661QPHPRQ1	HTQFP	PHP	48	1000	330.0	16.4	9.6	9.6	1.5	12.0	16.0	Q2

TAPE AND REEL BOX DIMENSIONS



*All dimensions are nominal

Device	Package Type	Package Drawing	Pins	SPQ	Length (mm)	Width (mm)	Height (mm)
TPS92661QPMPRQ1	HTQFP	PHP	48	1000	336.6	336.6	31.8

PHP (S-PQFP-G48)

PowerPAD™ PLASTIC QUAD FLATPACK

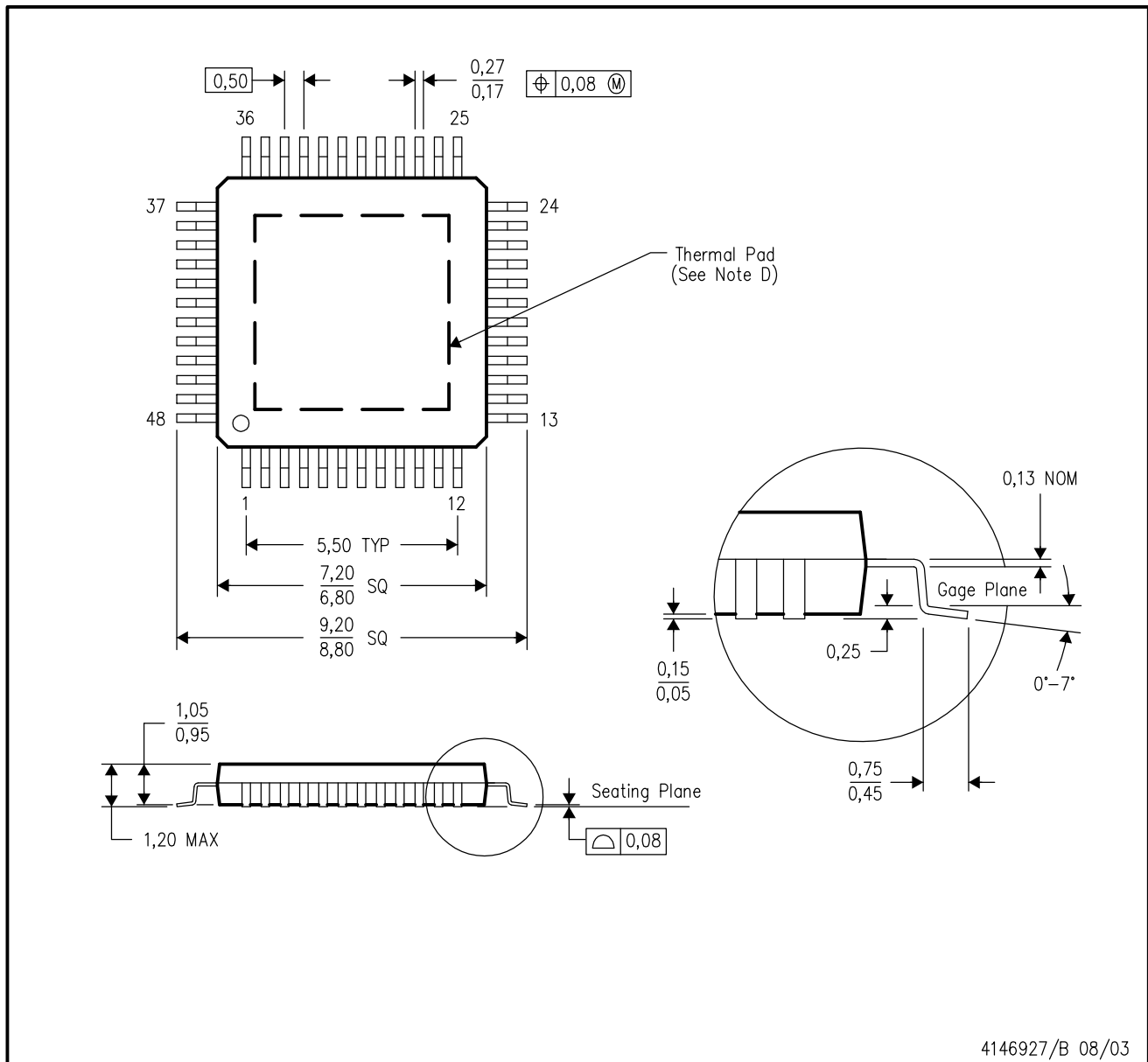

- NOTES:
- A. All linear dimensions are in millimeters.
 - B. This drawing is subject to change without notice.
 - C. Body dimensions do not include mold flash or protrusion
 - D. This package is designed to be soldered to a thermal pad on the board. Refer to Technical Brief, PowerPad Thermally Enhanced Package, Texas Instruments Literature No. SLMA002 for information regarding recommended board layout. This document is available at www.ti.com <<http://www.ti.com>>.
 - E. Falls within JEDEC MS-026

PowerPAD is a trademark of Texas Instruments.

THERMAL PAD MECHANICAL DATA

PHP (S-PQFP-G48)

PowerPAD™ PLASTIC QUAD FLATPACK

THERMAL INFORMATION

This PowerPAD™ package incorporates an exposed thermal pad that is designed to be attached to a printed circuit board (PCB). The thermal pad must be soldered directly to the PCB. After soldering, the PCB can be used as a heatsink. In addition, through the use of thermal vias, the thermal pad can be attached directly to the appropriate copper plane shown in the electrical schematic for the device, or alternatively, can be attached to a special heatsink structure designed into the PCB. This design optimizes the heat transfer from the integrated circuit (IC).

For additional information on the PowerPAD package and how to take advantage of its heat dissipating abilities, refer to Technical Brief, PowerPAD Thermally Enhanced Package, Texas Instruments Literature No. SLMA002 and Application Brief, PowerPAD Made Easy, Texas Instruments Literature No. SLMA004. Both documents are available at www.ti.com.

The exposed thermal pad dimensions for this package are shown in the following illustration.

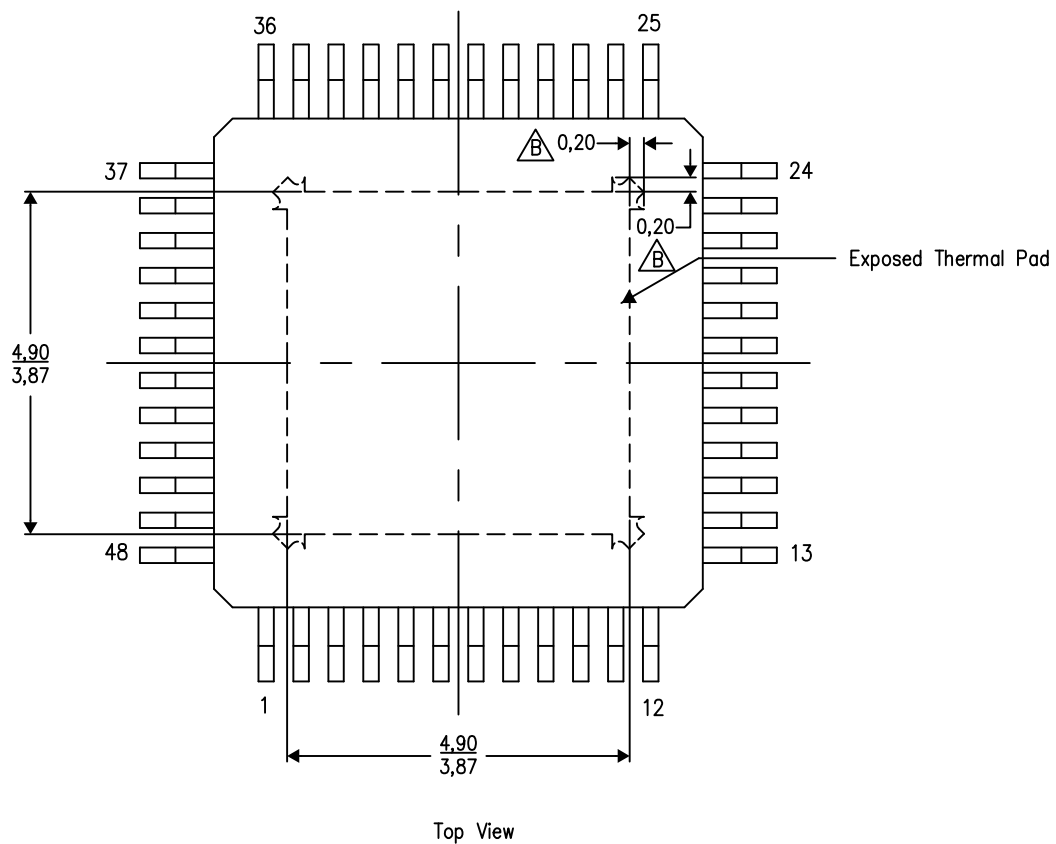

Exposed Thermal Pad Dimensions

4206329-4/0 05/14

NOTE: A. All linear dimensions are in millimeters

 Tie strap features may not be present.

PowerPAD is a trademark of Texas Instruments

PHP (S-PQFP-G48)

PowerPAD™ PLASTIC QUAD FLATPACK

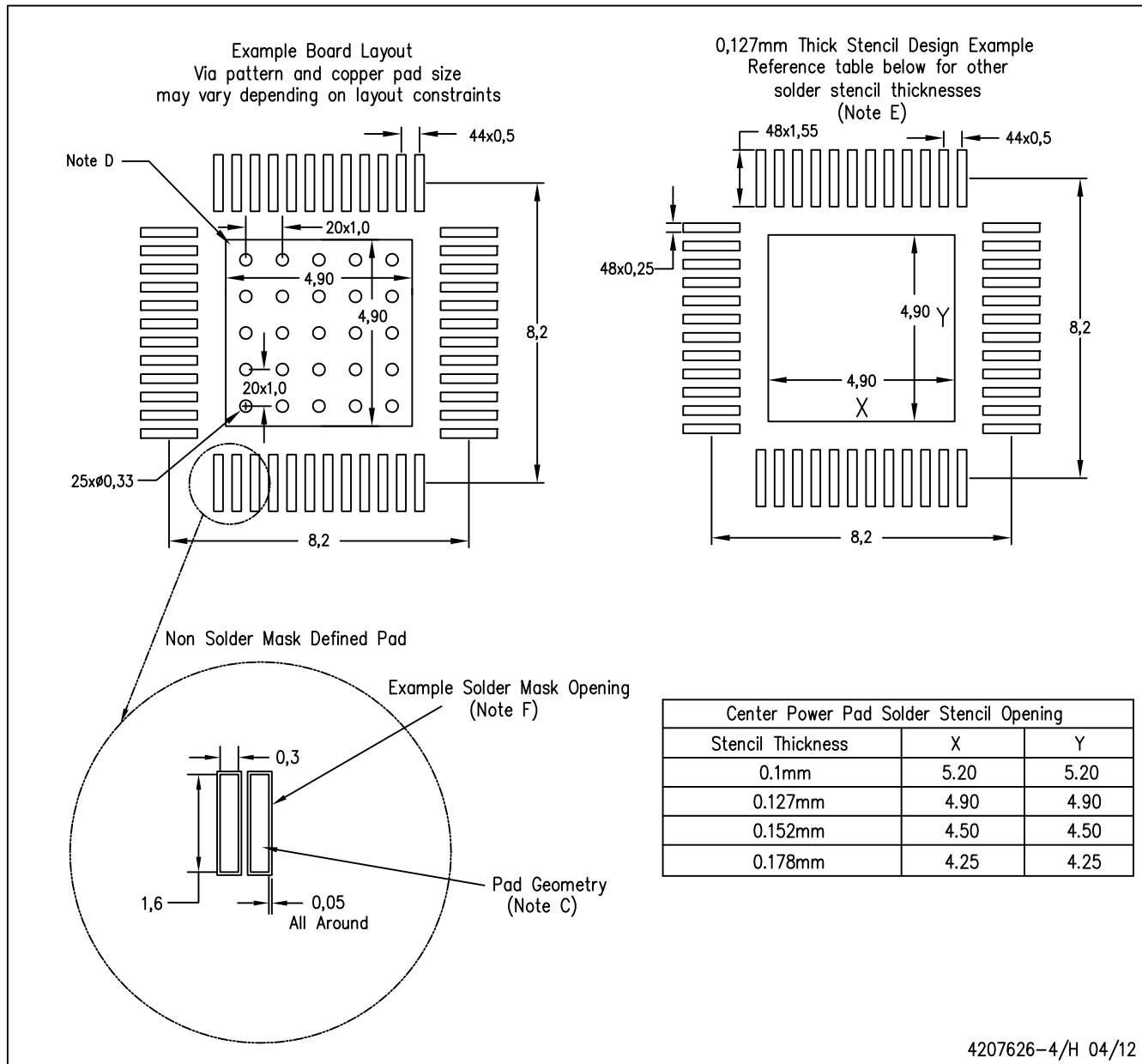

- NOTES:
- A. All linear dimensions are in millimeters.
 - B. This drawing is subject to change without notice.
 - C. Publication IPC-7351 is recommended for alternate designs.
 - D. This package is designed to be soldered to a thermal pad on the board. Refer to Technical Brief, PowerPAD Thermally Enhanced Package, Texas Instruments Literature No. SLMA002, SLMA004, and also the Product Data Sheets for specific thermal information, via requirements, and recommended board layout. These documents are available at www.ti.com <<http://www.ti.com>>.
 - E. Laser cutting apertures with trapezoidal walls and also rounding corners will offer better paste release. Customers should contact their board assembly site for stencil design recommendations. Refer to IPC 7525 for stencil design considerations.
 - F. Customers should contact their board fabrication site for recommended solder mask tolerances and via tenting options for vias placed in the thermal pad.

PowerPAD is a trademark of Texas Instruments

IMPORTANT NOTICE

Texas Instruments Incorporated and its subsidiaries (TI) reserve the right to make corrections, enhancements, improvements and other changes to its semiconductor products and services per JESD46, latest issue, and to discontinue any product or service per JESD48, latest issue. Buyers should obtain the latest relevant information before placing orders and should verify that such information is current and complete. All semiconductor products (also referred to herein as "components") are sold subject to TI's terms and conditions of sale supplied at the time of order acknowledgment.

TI warrants performance of its components to the specifications applicable at the time of sale, in accordance with the warranty in TI's terms and conditions of sale of semiconductor products. Testing and other quality control techniques are used to the extent TI deems necessary to support this warranty. Except where mandated by applicable law, testing of all parameters of each component is not necessarily performed.

TI assumes no liability for applications assistance or the design of Buyers' products. Buyers are responsible for their products and applications using TI components. To minimize the risks associated with Buyers' products and applications, Buyers should provide adequate design and operating safeguards.

TI does not warrant or represent that any license, either express or implied, is granted under any patent right, copyright, mask work right, or other intellectual property right relating to any combination, machine, or process in which TI components or services are used. Information published by TI regarding third-party products or services does not constitute a license to use such products or services or a warranty or endorsement thereof. Use of such information may require a license from a third party under the patents or other intellectual property of the third party, or a license from TI under the patents or other intellectual property of TI.

Reproduction of significant portions of TI information in TI data books or data sheets is permissible only if reproduction is without alteration and is accompanied by all associated warranties, conditions, limitations, and notices. TI is not responsible or liable for such altered documentation. Information of third parties may be subject to additional restrictions.

Resale of TI components or services with statements different from or beyond the parameters stated by TI for that component or service voids all express and any implied warranties for the associated TI component or service and is an unfair and deceptive business practice. TI is not responsible or liable for any such statements.

Buyer acknowledges and agrees that it is solely responsible for compliance with all legal, regulatory and safety-related requirements concerning its products, and any use of TI components in its applications, notwithstanding any applications-related information or support that may be provided by TI. Buyer represents and agrees that it has all the necessary expertise to create and implement safeguards which anticipate dangerous consequences of failures, monitor failures and their consequences, lessen the likelihood of failures that might cause harm and take appropriate remedial actions. Buyer will fully indemnify TI and its representatives against any damages arising out of the use of any TI components in safety-critical applications.

In some cases, TI components may be promoted specifically to facilitate safety-related applications. With such components, TI's goal is to help enable customers to design and create their own end-product solutions that meet applicable functional safety standards and requirements. Nonetheless, such components are subject to these terms.

No TI components are authorized for use in FDA Class III (or similar life-critical medical equipment) unless authorized officers of the parties have executed a special agreement specifically governing such use.

Only those TI components which TI has specifically designated as military grade or "enhanced plastic" are designed and intended for use in military/aerospace applications or environments. Buyer acknowledges and agrees that any military or aerospace use of TI components which have **not** been so designated is solely at the Buyer's risk, and that Buyer is solely responsible for compliance with all legal and regulatory requirements in connection with such use.

TI has specifically designated certain components as meeting ISO/TS16949 requirements, mainly for automotive use. In any case of use of non-designated products, TI will not be responsible for any failure to meet ISO/TS16949.

Products

Audio	www.ti.com/audio
Amplifiers	amplifier.ti.com
Data Converters	dataconverter.ti.com
DLP® Products	www.dlp.com
DSP	dsp.ti.com
Clocks and Timers	www.ti.com/clocks
Interface	interface.ti.com
Logic	logic.ti.com
Power Mgmt	power.ti.com
Microcontrollers	microcontroller.ti.com
RFID	www.ti-rfid.com
OMAP Applications Processors	www.ti.com/omap
Wireless Connectivity	www.ti.com/wirelessconnectivity

Applications

Automotive and Transportation	www.ti.com/automotive
Communications and Telecom	www.ti.com/communications
Computers and Peripherals	www.ti.com/computers
Consumer Electronics	www.ti.com/consumer-apps
Energy and Lighting	www.ti.com/energy
Industrial	www.ti.com/industrial
Medical	www.ti.com/medical
Security	www.ti.com/security
Space, Avionics and Defense	www.ti.com/space-avionics-defense
Video and Imaging	www.ti.com/video

TI E2E Community

e2e.ti.com